

# Installation, Operation & Maintenance Manual

**RENNER**  
Kompressoren 

## RS-B



**Please read carefully before commissioning and follow instructions. Keep in a safe place for future use.**

RENNER GmbH Kompressoren  
Emil-Weber Str. 32  
D-74363 Gueglingen  
Tel: +49 (0)7135 931 93 0  
Fax: +49 (0)7135 931 93 50  
info@renner-kompressoren.de  
www.renner-kompressoren.de

English Version V 06 / 2016

**GB**

## Table of contents

---

### Chapter 0 General information

Nr.	Subject	page
0.1	General information	0-2
0.2	Structure and use of this manual	0-4
0.3	Intended usage / misuse	0-6
0.4	Requirement of the user	0-7
0.5	Personnel responsibilities	0-8

---

### Chapter 1 Safety advice

Nr.	Subject	page
1.1	Symbols	1-2
1.2	Basic safety advice	1-3
1.3	Accident conduct	1-6

---

### Chapter 2 Machine description

Nr	Subject	page
2.1	Authorised access points	2-2
2.2	Safety devices	2-4
2.3	Compressor unit	2-5
2.4	Instrumentation panel RENNERlogic	2-9
2.5	RENNERtronic Control (optional)	2-10
2.6	RENNERtronic plus Control (optional)	2-11
2.7	Refrigeration dryer (optional)	2-12

---

## Table of contents (continuation)

---

### Chapter 3 Installation & putting into operation

Nr.	Subject	page
3.1	Compressor installation	3-2
3.2	Connections	3-3
3.3	Putting into operation	3-5

---

### Kapitel 4 Operating / normal use

Nr.	Subject	page
4.1	Control instrumentation RENNERlogic	4-2
4.2	Control instrumentation RENNERtronic	4-3
4.3	Control instrumentation RENNERtronic plus	4-5
4.4	Compressor startup / normal use	4-6
4.5	To stop the compressor	4-8
4.6	Failures during operation	4-10

---

**Chapter 5**  
**Maintenance**

<b>Nr.</b>	<b>Subject</b>	<b>page</b>
5.1	What to take into account	5-2
5.2	Remove faults	5-4
5.3	Venting the compressor system	5-5
5.4	Cleaning work	5-6
5.5	Checking oil level	5-7
5.6	Change of oil filter	5-8
5.7	Changing oil	5-9
5.8	Cleaning oil level sight glass	5-10
5.9	Cleaning oil cooler	5-11
5.10	Checking safety valve	5-12
5.11	Tensioning and changing drive belt(s)	5-13

---

**Chapter 6**  
**Decommissioning**  
**and disposal**

<b>Nr.</b>	<b>Subject</b>	<b>page</b>
6.1	Decommissioning of plant	6-2
6.2	Re-commissioning after storage	6-4
6.3	Shut-down and disposal	6-5

---

**Appendixes**

<b>Nr.</b>	<b>Subject</b>	
AT	Data sheet	
ACE	CE Conformity Declaration	
AW1	Maintenance check	
AW2	Motor bearings	
AW3	Maintenance work	
ADS	Pressure switch	
AKT	Refrigeration dryer (optional)	

---

# Chapter 0

## General Information

---

### Contents

Hereunder you will find general information relating to the following subjects:

- Utilisation of the INSTALLATION, OPERATION & MAINTENANCE MANUAL
  - Compressor Operation and Usage
  - Personnel responsibilities
- 

### Survey

This chapter relates to the following subjects:

No.	Subject	Page
0.1	General information	0-2
0.2	Structure and use of the manual	0-4
0.3	Intended Usage	0-5
0.4	Requirement of the user	0-6
0.5	Personnel responsibilities	0-7

---

## 0.1 General Information

---

**Contents** General information regarding this manual.

---

**Validity** This manual is applicable to the following compressor:

Compressor Detail	Classification
Type	Screw compressor
Year of construction	
Serial number	
Model	
Location	

---

**Manufacturer** RENNER GmbH compressors  
Emil-Weber-Strasse 32  
D-74363 Gueglingen

---

**Date of issue** June 2016

---

**Safe-keeping and completeness**

- This manual should be kept in a clean safe condition and should be readily available to authorised personnel at all times.
- Do not remove any pages from this manual. Any lost or mislaid pages should be replaced especially if they relate to health and safety matters.

---

*Continuation next page*

## **0.1 General Information (Continuation)**

---

### **Copyright**

This documentation contains copyrighted information. Without prior consent of RENNER GmbH this information must not be photocopied, duplicated, translated or put on data carrier neither as a whole or part document. RENNER GmbH reserves all further rights.

### **Modification of the compressor**

For safety reasons any modification or alteration may be permitted only after having received the agreement of the manufacturer. If modifications are made without the prior agreement of the manufacturer all warranties and manufacturers responsibilities will be invalidated.

In these cases, the process for conformity evaluation pursuant to 2006/42/EC for all components may need to be carried out again.

---

### **Suppliers' documents \*)**

The following suppliers documents are part of this manual and must be kept save and related to:

<b>Documents for</b>	<b>manufacturer</b>
RENNERtronic controller	RENNER GmbH
Operation manual air dryer	RENNER GmbH D-74363 Güglingen

\*) in case the compressor is equipped with any of these options



## 0.2 Structure and use of this manual

---

### Contents

The following information relates to the structure and use of this manual.

---

### Chapter

This manual contains the following chapters:

Chapter	Summary
0	<ul style="list-style-type: none"><li>● General Information regarding:<ul style="list-style-type: none"><li>– the manual,</li><li>– its usage</li><li>– personnel responsibilities</li></ul></li></ul>
1	<ul style="list-style-type: none"><li>● Definition of the symbols used</li><li>● Basic safety instructions</li></ul>
2	<ul style="list-style-type: none"><li>● Description and function of the compressor</li></ul>
3	<ul style="list-style-type: none"><li>● Operating the compressor</li></ul>
4	<ul style="list-style-type: none"><li>● Maintenance hints</li></ul>
A(xy)	<ul style="list-style-type: none"><li>● Appendix (es)</li></ul>

---

### Numbering of pages

The pages have been consecutively numbered according to the chapter:

Example: 3-2

Signifies: Chapter 3, *Page 2*

Example: AS-1

Signifies: Appendix and „S“ for control, *Page 1*

---

*Continuation next page*

## 0.3 Intended usage / misuse

---

The intended usage of the compressor is described

---

**Definition:  
authorized persons**

Persons are regarded as authorized, when they have received adequate training/instruction and is then charged with defined work on or with the compressor... Keys to the guard doors must only be made accessible to authorized persons.

---

**Intended usage**

The compressor should only be used according to the manufacturer recommendations in conjunction with the following bullet points.

- The compressor must be used only for the compression of technically clean air without any detrimental or explosive additives or impurities.  
Ambient temperature must be below 40°C\*.
  - Authorized persons only are allowed to work on the compressor
  - The machine must only be operated with the safety devices installed
  - The safety\* and operating advice contained in this manual must be observed
  - Any instructions given by the operating company must be observed
  - The legal accident prevention rules must be respected
- 

**Misuse**

Misuse is regarded as:

- Operation by non-authorized persons
  - Operation by disregarding rules and regulations
  - Operation without corresponding treatment / cleansing of the compressed air in the field of foodstuffs and breathing air
  - Operation with defective safety-devices or those deactivated or modified
- 

\* please consult your dealer or the manufacturer with details in case the ambient temperature is higher in your compressor room

## **0.4 Requirement of the user**

---

### **Contents**

Hereafter the duties and obligations of the user are outlined when operating the machines

---

### **Safety of the plant**

The user has to particularly ensure that

- the compressor must be used only according to Manufacturer recommendations in conjunction with all current health and safety regulations
  - the compressor must be operated only when in faultless condition and fully functional
  - the integrated safety devices are regularly serviced and are fully functional
  - only adequately qualified and authorized personnel operate, service, and repair the compressor
- 

### **Protection of staff**

The operating company must ensure that the personal protective equipment required is available for

- the operating personnel,
  - the service and maintenance personnel
  - the maintenance and repair personnel and that it is used accordingly
- 

### **Briefing and training**

The operating company must ensure:

- that prior to start up all personnel who will maintain, service or operate the compressor are fully aware of the current personal and environmental safety regulations and procedures.  
Annual personnel update of safety procedures would be recommended
  - the complete manual must always be available at the site of the compressor in a readable condition
  - that personnel are aware of the location of the manual, the content and particularly the safety chapters.
  - the safety and warning advices mounted are not taken away or made illegible
-

## **0.5 Personnel responsibilities**

---

### **Contents**

The requirements in regard to personnel responsibilities are as follows.

---

### **Duty of operating personal**

The personnel must carry out the following duties:

- to control and inspect the compressor as to its faultless and safe function (see chapter 2.1)
  - to operate the compressor according to the operating points previewed
  - to recognize and delete or report respectively disturbances and irregularities.
- 

### **Responsibilities of operating personnel**

In order to carry through the requisitions the service personal must accomplish the following requirements

- The operator (of the compressor) must have received instructions from the operating company as to the labor protection law.
  - The operator must have a clear understanding of the instructions given by the operating company and must carry them out.
- 

### **Duties of the maintenance personnel**

The service and maintenance personnel must comply with the following duties:

- carry through regular inspection and maintenance work
  - up-keep of the compressor
  - carry through test runs of the machine
  - check the integrated safety devices
- 

### **Requirement of maintenance personnel**

The following qualifications are required in regard to maintenance personnel:

- The maintenance personnel must have successfully passed a test as skilled (machinery) labour - or equivalent.
- The personnel must comply with the maintenance instructions.

# Chapter 1

## Safety Advice

---

### Contents

This chapter informs you about

- Definition of the symbols used.
  - Basic advice as to the safe handling of the compressor.
  - Advice regarding accidents.
- 



### Important advice!

It must be clearly understood that the safety advice given in this manual should only be used as an additional aid to the national safety accident prevention rules and laws currently in force.

Existing accident prevention rules and regulations must be retained and adhered to at all times.

---

### Survey

This chapter relates to the following subjects:

No	Subject	Page
1.1	Symbols	1-2
1.2	Basic safety advice	1-3
1.3	Accident conduct	1-6

---

## 1.1 Symbol

---

### Contents

### Symbol definitions

---



#### **Danger!**

This symbol relates to the danger of life and health of people

Dangers to life will be particularly related to by using the expression: **danger for life.**

---



#### **Danger!**

This symbol relates to danger for life and health of people due to electric voltage.

---

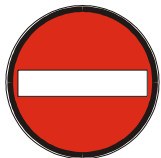

#### **Attention!**

This symbol is a sign of danger for machine, material or the environment

---



#### **Advice!**

This symbol is to indicate important advice and information which contribute to your own safety, as well as to the better understanding of the compressor operation.

---



#### **Disposal!**

This symbol indicates advice as to the disposal of machinery parts and operating materials.

---

## 1.2 Basic safety advice

---

### Contents

Hereafter you will find basic safety advice for the safe handling of the compressor.

---



### Danger!

To minimise risk of personal injury, damage to equipment or property, strictly follow the remedial actions stated below.

Possible danger	Remedial action
<p><b>Remaining dangers</b>                      The screw compressor has been designed and built according to latest technical standards and according to recognized safety regulations and is equipped with corresponding safeguarding equipment.                      However, remaining risks cannot be excluded.</p> <p>These dangers will be explained in this chapter.</p> <p>Endangerment of people due to lack of qualification and/or operational faults of the service personnel.</p> <p><b>Explanation:</b>                      Operational faults may cause personal injury, or damage to equipment and property.</p>	<p>You should only operate this equipment</p> <ul style="list-style-type: none"> <li>● Having the qualification necessary</li> <li>● Having received complete instructions from the Operating Company</li> <li>● Having completely read and understood this MANUAL</li> <li>● Before any maintenance or service work is carried out the <b>RED STOP</b> button must be pressed. The incoming electrical supply to the compressor must also be switched off and isolated.</li> </ul>



**Protective gloves and protective goggles must be worn during some of the maintenance work. Please observe the corresponding advice**

---

## 1.2 Basic safety advice (continuation)

---



### Danger!

Please strictly follow the under mentioned safety advice to avoid the danger of electrical shock or personal injury.

Possible danger	Remedial actions
<p><b>Danger of life</b> Danger to people by an electric shock.</p> <p><b>Explanation:</b> The machine operates (as standard) at a voltage of 400 V with an adequately high amperage. As voltages of more than 44 mA can be fatal, corresponding precautions are required.</p>	<ul style="list-style-type: none"><li>● Do not touch live cables or connections.</li><li>● In case of damaged cables report immediately to the maintenance personnel.</li><li>● Ensure all doors to electrical installations are closed securely.</li><li>● Always isolate electrical supply before starting any maintenance work on the compressor.</li><li>● Only trained personnel must carry out maintenance and service work.</li><li>● Wear rubber soled safety shoes when working on the compressor electrical circuit.</li><li>● Make sure that during maintenance or service work no third party may switch on the circuit breaker</li></ul>



**There are no open flames and no sparks allowed at the site of operation.**



## 1.2 Basic safety advice (continuation)



### Attention!

To minimise risk of personal injury, damage to equipment or property, strictly follow the remedial actions stated below.

Possible damage	Measures for prevention
Physical injury of the personnel and damage to the compressor due to removal or evasion of protective devices	<ul style="list-style-type: none"> <li>Do not remove or make inoperative any safety device</li> <li>Rectify defects immediately they are recognised</li> <li>Electrical work/repairs must be carried out by a qualified electrician only</li> </ul>
Damage to the compressor due to overloading	<ul style="list-style-type: none"> <li>Do not exceed the technical limit values stipulated</li> </ul>
Burns through hot compressor parts	<ul style="list-style-type: none"> <li>Do not touch compressor parts immediately after having opened the doors of the canopy</li> </ul>
Burns through hot lubrication oil when topping up or changing oil	<ul style="list-style-type: none"> <li>Turn the oil filler cap slowly anticlockwise during the first 5 rotations until a tangible "snap-point". Thus the remaining pressure will be slowly relieved (see also chapter 5.7: Changing Oil)</li> </ul>
Possible eye and skin burn due to hot condensate spurt	<ul style="list-style-type: none"> <li>Let the compressor sufficiently cool down and handle with great care before disconnecting it from the c.a. system.  <b>Wear protective goggles</b></li> </ul>
Danger through compressed air  <b>Danger of life</b> Compressed air may severely injure human and domestic animals	<ul style="list-style-type: none"> <li>Do not bring compressed air to bear on any creature</li> </ul>

## 1.3 Accident Conduct

---

### Contents

Hereafter you will get to know which measures must be taken at accidents or disasters (e.g. fire or explosion)

---

### Preparations for appropriate help at accidents

Please undertake the following measures at regular time intervals so as to be prepared in case of an accident:

- Take part on regular basis in First - Aid courses in order to brush up your knowledge.
  - Get yourself regularly informed about the possibilities which are at your disposal in regards to rescue facilities for First Aid in your company
  - Safe-guard a list at your work place containing the telephone numbers required as well as the contact person.
- 

### Accident conduct

At an accident, proceed in the following sequence:

Action	If	Then
1	there are injured people	administer first aid if you are a trained first aider?
2	there are injuries to people and damage to property	<b>inform the rescue team of the severity of injuries and type of damage to property.</b>
3	the disaster (fire) has happened	<ul style="list-style-type: none"> <li>● leave the machine immediately</li> <li>● use the marked emergency exits and escape facilities.</li> <li>● do not use elevators/lifts!</li> </ul>
4	there are injuries to people, damage to equipment or buildings	inform your supervisor immediately or another person from the list of company first aiders or safety officers. This list should be clearly visible in the working area.

---

# Chapter 2

## Machine description

---

### Content

This chapter covers the following:

- definition of the safe access points for operating the compressor,
  - overview of the compressor and its control instrumentation, and
  - technical data.
- 

### Overview

This chapter is subdivided as follows:

No.	Subject	Page
2.1	Authorised access points	2-2
2.2	Safety devices	2-4
2.3	Compressor unit	2-5
2.4	Instrumentation panel RENNERlogic	2-9
2.5	RENNERtronic Control (optional)	2-10
2.6	RENNERtronic plus Control (optional)	2-11
2.7	Refrigeration dryer (optional)	2-12

---

## 2.1 Authorised access points

---

### Content

This section defines the safe access points for operating the compressor and for carrying out minor inspection and maintenance work.

---

### Important Note!

Other access points are not intended for operating the compressor and are therefore not permitted as operator stations! Safe operation can only be guaranteed from the operator terminals specified. Work on the switch box and electrical installations may only be carried out by qualified electricians.

---

**Figure**  
**Access points**

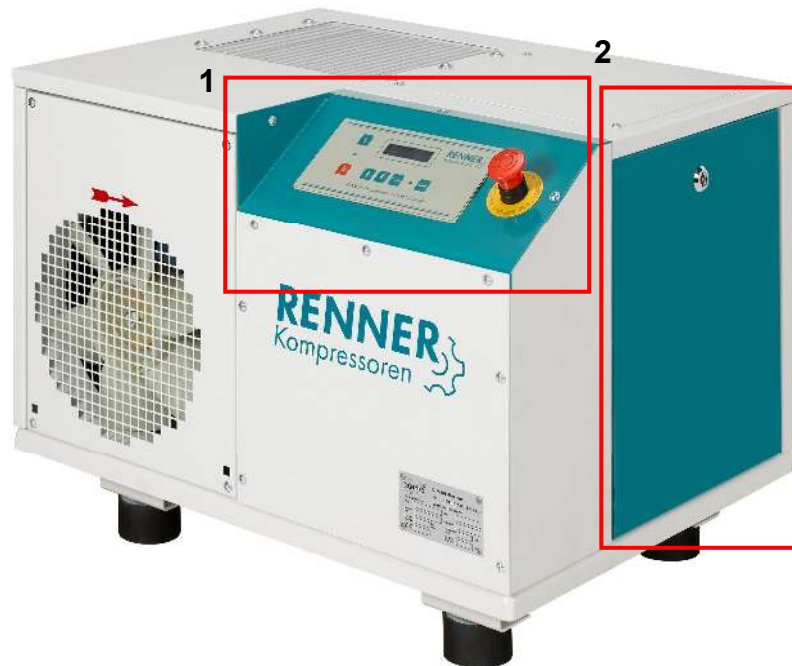

*Continued overleaf*

## 2.1 Authorised access points (cont.)

---

### Description of the access points

The following access points only are provided for the operation of the machine:

No.	Operation ...	Actions permitted
1	... of the control panel	<ul style="list-style-type: none"><li>● Check working pressure</li><li>● Check oil and operating temperature</li><li>● Read operating hours</li><li>● Switch compressor on</li><li>● Emergency stop or shut-down of compressor</li></ul>
2	... of the safety devices	<ul style="list-style-type: none"><li>● Carry out inspection and minor maintenance work</li></ul>

---

## 2.2 Safety devices

### Content

This section provides an overview of the major compressor elements and their functions.

### Figure safety devices

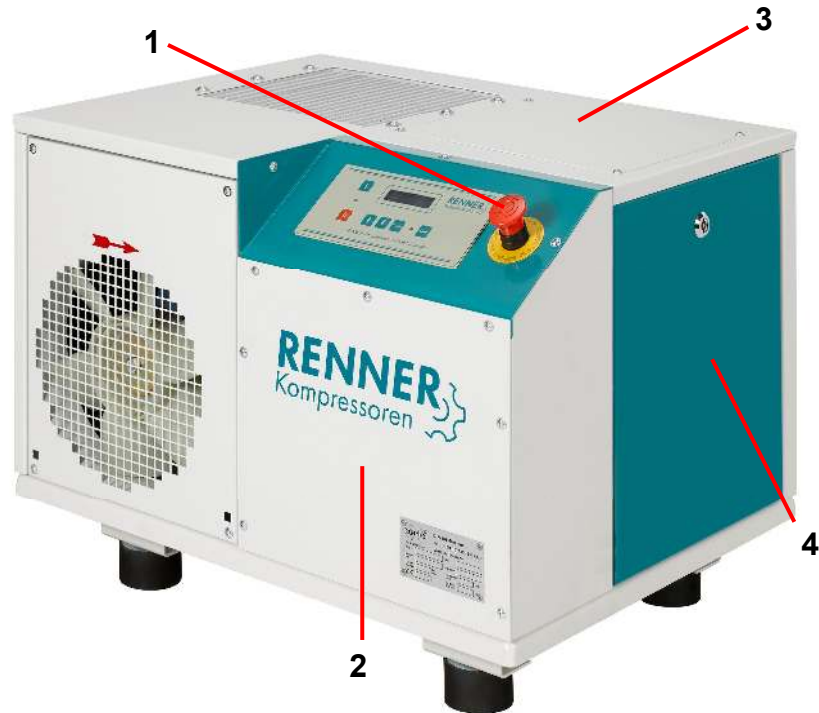

### Description of the safety devices

The following safety devices are fitted to the outside of the compressor:

Item	Description	Function
1	Emergency stop	Stops compressor immediately in emergency
2	Electric panel door	Guard door on control box to be opened by qualified electricians only <b>CAUTION: Danger to life! Electrical voltage!</b>
3	Top lid	Access to air filter and oil trap cartridge
4	Side panels	Access to motor, drive belt, oil filter, oil filler neck, pressure switch and control valve

## 2.3 Compressor unit

Figure  
compressor unit

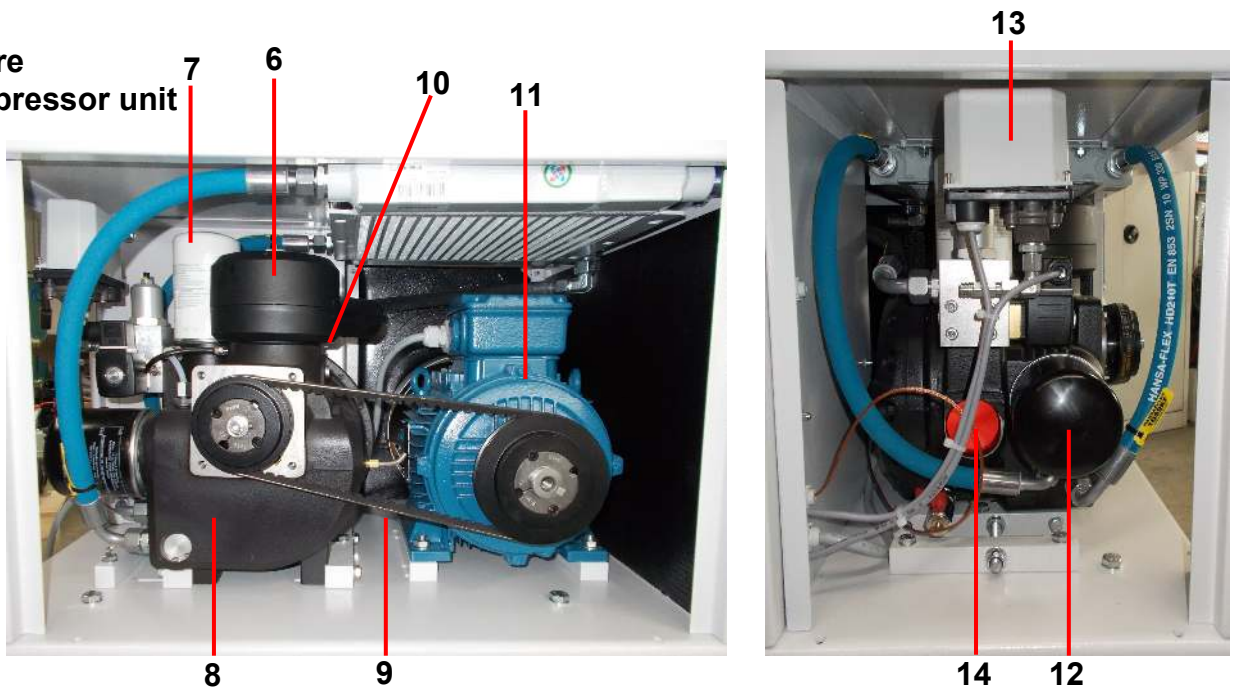

### Description of the compressor unit

After removing the front walls of the compressor, you will see the most important components of the unit:

Item	Description	Function
6	<b>Suction air filter cartridge</b>	Is used to filter suction air
7	<b>Separator cartridge</b>	Filters the finest residue oil from the compressed air after pre-separation
8	<b>Air end</b>	Generate air pressure
9	<b>V-belt</b>	Power transfer
10	<b>Safety valve</b>	Pressure limitation
11	<b>Electro-motor</b>	Drive
12	<b>Oil filter</b>	Purifies the compressor oil
13	<b>Pressure switch</b>	Controls the switch-on and switch-off pressure
14	<b>Oil filter neck</b>	Oil level control and refill

## 2.3 Compressor unit (cont.)

---

### Description aggregate components

#### **Air end (item 8)**

The direction of rotation of the air end is to the left (anti-clockwise) when looking from the front-side on to the shaft (see picture). Pay attention to the directional arrow on the side of the air end with the sign D.

#### **Suction air filter (item 6)**

The suction air filter is directly mounted on to the suction stud of the suction regulator.  
The dry micro-filter with a rating of 10 µm filters the intake air.

#### **Pressure switch (electric)**

The pressure switch is directly connected to the outlet of the machine. It controls the suction regulator. The values for  $p_{\max}$  and  $p_{\min}$  are set at this switch.

$p_{\max}$ : is the upper service pressure at which the unit normally stops pumping

$p_{\min}$ : is the lower service pressure at which the unit normally starts pumping again.



The pressure switch has been correctly set in the factory. Authorised personnel must only carry out adjustments to the pressure switch.

#### **Suction regulator**

The suction regulator is directly connected to the air end. It controls the air volume sucked in by the compressor via the air suction filter.

Function of the suction regulator:

The suction regulator comprises of one main valve. This operates as a control valve and at the same time as a hermetically sealed isolator valve. At full load the suction cross-section is fully opened.

When the machine stops this valve closes quickly and thus the suction cross section is locked altogether.

The multi-functions of the regulator are ensured by just one flange mounted control unit.

#### **Minimum pressure valve**

The minimum pressure valve is situated at the outlet of the compressor unit just before the air-after cooler.

It performs two tasks:

1) As a minimum pressure valve it prevents a loss of pressure (in the air end) when no counter pressure in the air-mains is available. A minimum pressure is necessary in order to safeguard lubrication of the air end.



## 2.3 Compressor unit (continuation)

### Description unit components (contd.)

2) As a “non return valve“ it prevents at the same time the reverse flow of compressed air from the air mains or the air vessel, back into the compressor unit. Due to this function the compressor unit is totally pressure relieved once it is stopped.

The valve operates automatically. The setting of the minimum pressure valve must only be done by persons authorised by the manufacturer.



### Oil separator cartridge (Item 7)

The oil separator cartridge is not only designed for filtering the oil from the compressed air, but serves at the same time to reclaim the residual oil after pre-separation as drops, formerly micro-distributed in the system. This cartridge is a spin on/off type and – by means of the connection nipple – is screwed on to the filter support of the oil re-claimer (see illustration below)

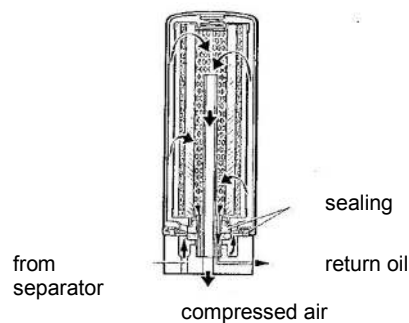

Illustration: oil separator cartridge

### Oil return scavenge window / oil return scavenge non-return valve

The oil return window (fitted to some air ends) is situated near to the oil separator cartridge and shows the scavenged oil coming from the a.m. cartridge.

When starting the compressor the scavenge window is filled with oil due to its accumulation during standstill. After a few minutes a mixture of oil and air can be observed. Separation of oil in the cartridge takes place.

If after a longer period of operating time no oil can be observed in the scavenge window, a disturbance may have happened e.g. a clogged borehole. As a consequence the oil separated will be carried over in the compressed air into the air mains/vessel.

**Only personnel authorised by the manufacturer are allowed to rectify such problems.**

## 2.3.2 Compression unit (continuation)

---

**Description:  
Compression unit  
components (con-  
tinuation)**

**Oil scavenge window / oil scavenge non-return valve**

The oil scavenge non-return valve prevents the oil separator cartridge from flooding by scavenging oil from the air end.

**Oil filter (item 12)**

The oil filter (cartridge) cleans the compressor oil from impurities. The cartridge is screwed on to the scavenge stud by hand. The efficiency of the filter is about 25 µm.

**Combistat**

The Combistat is a temperature indicator and control unit. It is built into the instrument panel. It monitors the maximum permissible service temperature of the unit, which is set at 110°C (red mark).

When this temperature is reached the electric circuit is disconnected and the unit stops automatically.

Do not bend the connecting line between the compressor and the Combistat, otherwise the electric circuit is interrupted.

**Safety valve (item 10)**

The safety valve is mounted on the oil re-claimer before the oil separator cartridge. It is set 1-2 bar above the max. gauged pressure. The safety valve blows off in case the final pressure is exceeded due to a fault somewhere in the system.

## 2.4 Instrumentation Panel RENNERlogic

Figure  
Instrumentation  
panel  
RENNERlogic

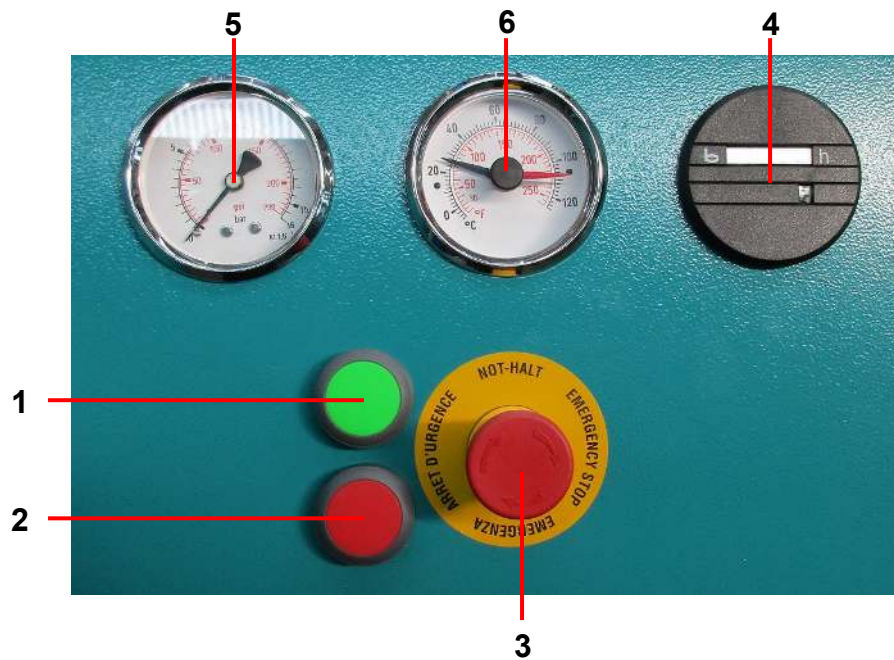

### Description of the Instrumentation panel RENNERlogic

The following controls are found on the instrumentation panel:

Item	Description	Function
1	<b>Start button</b>	Switches the compressor on
2	<b>Stop button</b>	Switches the compressor off
3	<b>Emergency stop</b>	Switches the compressor off in <b><u>case of emergency</u></b>
4	<b>Operating hour meter</b>	Counts the number of hours operated by the compressor
5	<b>Pressure gauge: Working pressure</b>	Indicates pressure ratios or excess pressure
6	<b>Combistat temperature indicator</b>	Indicates operating temperature and overheating

## 2.5 RENNERtronic Control (Optional)

### Content

The “RENNERtronic” controls and monitors the entire workings of the compressor. It is possible to set or change a number of parameters and functions.=> please also note the enclosed instructions

**Figure**  
**Control**  
**RENNERtronic**

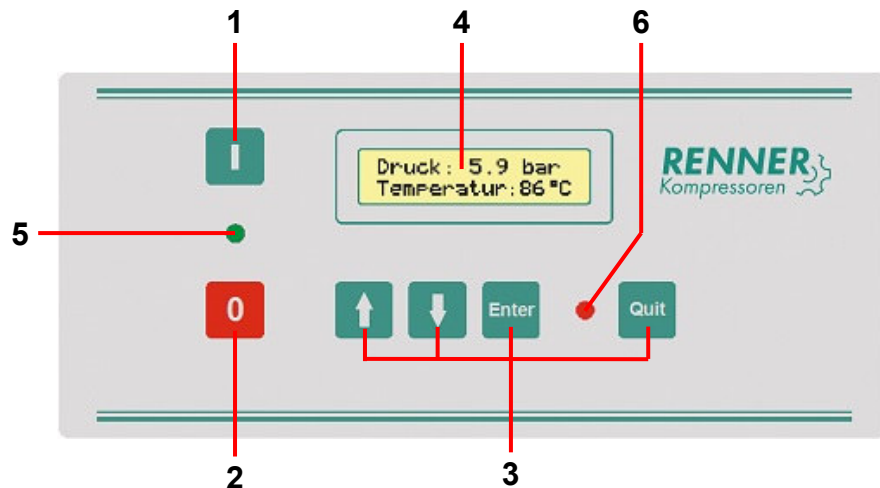

### Instrumentation components: Control RENNERtronic

The "RENNERtronic" control features the following instrumentation controls:

Item	Description	Function
1	<b>Compressor ON</b>	Switches the compressor on
2	<b>Compressor OFF</b>	Switches the compressor off
3	<b>Multiple function keys</b>	Navigates in the menus, sets parameters, etc.
4	<b>Display</b>	Displays the parameters
5	<b>LED (green)</b>	Service LED
6	<b>LED (red)</b>	Fault / maintenance LED



### Note!

Please see the explanations in Chapter 4 and the instruction manual for the “RENNERtronic” control.

## 2.6 RENNERtronic plus Control (Optional)

### Content

The “RENNERtronic plus” controls and monitors the entire workings of the compressor. It is possible to set or change a number of parameters and functions.=> please also note the enclosed instructions

**Figure**  
**Control**  
**RENNERtronic plus**

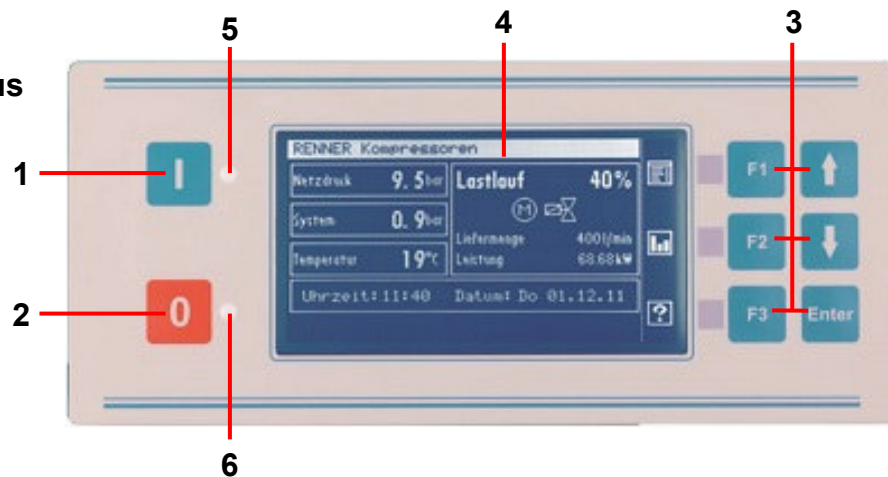

**Instrumentation**  
**components:**  
**Control**  
**RENNERtronic plus**

The "RENNERtronic plus" control features the following instrumentation controls:

Item	Description	Function
1	<b>Compressor ON</b>	Switches the compressor on
2	<b>Compressor OFF</b>	Switches the compressor off
3	<b>Multiple function keys</b>	Navigates in the menus, sets parameters, etc.
4	<b>Display</b>	Displays the parameters
5	<b>LED (green)</b>	Service LED
6	<b>LED (red)</b>	Fault / maintenance LED



### Note!

Please see the explanations in Chapter 4 and the instruction manual for the “RENNERtronic plus” control.

## 2.7 Refrigerant drier (optional)

---

### Contents

This section provides a brief overview of the refrigeration drier, installed as an optional feature.

### Diagrams of refrigerant drier

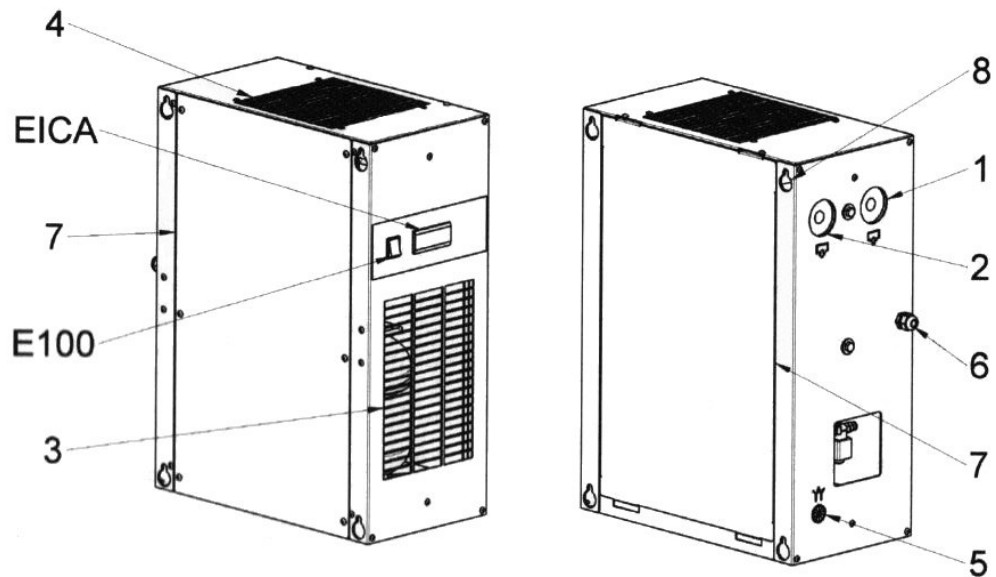

- 1.) Compressed air inlet
- 2.) Compressed air outlet
- 3.) Refrigerant air intake
- 4.) Refrigerant air outlet
- 5.) Steam trap

- 6.) Electrical connections
- 7.) Maintenance access
- 8.) Mounting holes
- E100.) On-off switch
- EICA.) Electronic regulator



### Hazard!

Observe the safety instructions in the separate operating manual for the refrigerant drier. It is especially dangerous to breathe in refrigerant vapour or come into contact with liquid refrigerant. Smoking is not permitted when working around the refrigerant drier since ash from cigarettes, or any other naked flame (e.g. when welding) combines with the refrigerant to produce poisonous vapours.

**Description**  
**Refrigerant drier**

The refrigerant drier also has a cooling unit to cool the compressed air. The unit also removes moisture from the compressed air. The resulting condensate is drained off using a condensate separator.



---

**Attention!**

Please see the explanations in chapter 4 and the KT Appendix as well as the manufacturer's instruction manual.

**Please note**

that the float of the steam trap is checked regularly and cleaned when necessary. Exact instructions regarding the procedure can be seen in the manufacturer's instruction manual in Point 5.1.3 Maintenance.

# Chapter 3

## Installation and commissioning

---

### Content

This chapter contains the most important information on transporting, installing and storing the compressor.

---

### General Information

The installation plan and the technical data of this specific screw compressor model can be ordered from RENNER GmbH. The compressor is delivered on a euro-pallet, packaged in a carton and labelled.



#### **Danger of tipping!**

The machine can tip over at an inclination of more than 10°! Use suitable transport means such as a forklift, lifting gear or loading harness. Support it from the side.

Unpacking the machine has no special requirements and the (interim) storage in the transport packaging is also not problematic. Protect the compressor against tilting over by storing it on level, firm ground.

---



Dispose of the packaging material (carton / marked sheets) separately.

---

### Overview

This chapter is subdivided into the following sections:

No.	Subject	Page
3.1	Compressor installation	3-2
3.2	Connections	3-3
3.3	Compressor start-up	3-5

---



## 3.1 Compressor installation

### Content

This section contains important instructions which you need to observe in order to safely install the compressor and to prevent damage or malfunction.



**Warning!**  
**Follow the safety instructions!**

Always remain outside the danger zone of a raised load!

### Compressor installation

Key word	Ensure that
<b>Installation site</b>	<ul style="list-style-type: none"> <li>• Surface: Flat, level, firm</li> <li>• Building ceilings: Check load bearing capacity</li> <li>• Air: As cool as possible, clean, frost-free, as little damp as possible Temp.: +5°C (41°F) - +40°C (104°F)*</li> <li>• Sufficient ventilation in the room</li> <li>• Air intake must be sufficiently unobstructed</li> <li>• Arrange the air intake opening in such a way that no loose items can be sucked in</li> <li>• The installation site is illuminated (to read off the instruments, carry out maintenance work...)</li> </ul>
<b>Lifting work</b>	<ul style="list-style-type: none"> <li>• Secure any loose, swinging or pivoting parts before lifting the compressor</li> <li>• Use suitable lifting gear (weight acc. to data sheet)</li> <li>• Always remain outside the danger zone of a raised load</li> </ul>
<b>Conduits, pressure pipes</b>	<ul style="list-style-type: none"> <li>• Remove all blank flanges, stoppers, covers and bags with drying agents before mounting conduits</li> <li>• Please ensure that the connection from the aftercooler to the compressed air system can expand as a result of heat and must be connected by means of a flexible hose.</li> </ul>
<b>Exhaust air</b>	<ul style="list-style-type: none"> <li>• An exhaust duct must at minimum have the diameter of the cooler outlet area and can be 3m in max. length with one bow of 90°; for longer ducts, use additional fans with 20% more power than the compressor fan</li> <li>• When installing several compressors please ensure that no compressor sucks in the heated exhaust air from another compressor</li> </ul>

\* Please ask your retailer in the event of higher temperatures.

## 3.2 Connections

---

### Content

This section covers important instructions which you need to observe in order to safely connect the compressor to the compressed air system as well as the electrical supply.

---



### Warning!

Before connecting the machine to the compressed air system, all conduits and hose connections inside the compressor must be checked and, if necessary, retraced.

For plants with pressure tanks, an acceptance check of the air collection tank must be made by a compressed air tank expert before commissioning.  
 Start an inspection log!

### A Compressed air connection

The system has all the required conduits and is ready for operation.

The following must be observed when connecting to the compressed air system:

### Compressed air connection

Key word	Ensure that
<b>Pressure</b>	<ul style="list-style-type: none"> <li>• Suitable screws and conduits are used for the operating pressure</li> <li>• The end pressure of the system is not higher than stated on the rating plate.</li> <li>• A non-return valve between the machine and the compressed air system is not required as it has already been integrated in the machine.</li> </ul>
<b>Connection</b>	<ul style="list-style-type: none"> <li>• Connect the system without voltage and isolated against vibrations to the compressed air system e.g. by using a flexible hose</li> </ul>
<b>Shut-off valve</b>	<ul style="list-style-type: none"> <li>• The additional installation of a shut-off valve is recommended to facilitate maintenance tasks at the compressor without de-pressurising the compressed air system.</li> </ul>
<b>Condensate</b>	<ul style="list-style-type: none"> <li>• An automatic steam trap can be integrated behind the after cooler for improved condensate separation from the compressed air</li> </ul>

---

## 3.2 Connections (continuation)

### B Electrical connection



**Attention!** All wiring work on the controls, and the compressors have to be carried out in consideration of the 5 safety rules.

**Five safety rules:**

Before starting work

- switch off
- lock against reclosure
- check that lines and equipment dead
- ground and short circuit phases
- cover, partition or screen of adjacent line sections

Only the connection to the electricity supply is now required for the machine which is now ready to use with all conduits installed.

**The machine must only be connected by an electrician!**

The following must be observed when connecting to the mains supply:

#### Electrical connection

Key word	Ensure that
<b>Voltage</b>	<ul style="list-style-type: none"> <li>• The machine is only connected to the voltage stated on the engine rating plate</li> </ul>
<b>Rotation</b>	<ul style="list-style-type: none"> <li>• The rotational direction is observed under all circumstances! Based on the attached arrows.</li> <li>• Checking the rotational direction see chap. 3.3/3.4. Not necessary for frequency-controlled compressors</li> </ul>
<b>Fuses</b>	<ul style="list-style-type: none"> <li>• Customer to install the main fuse and circuit breaker with the EMERGENCY STOP function; these must be able to switch at least 1.1 times the motor output and must be clearly allocated to the machine</li> <li>• Ensure that the mains supply is sufficiently secured (see data sheet)</li> </ul>
<b>Connection</b>	<ul style="list-style-type: none"> <li>• The supply cable must be situated such that there is no danger of tripping over it</li> <li>• Insert the cable with leads L1, L2, L3, N and PE through the PG connection in the connection box Connect the leads to terminals L1, L2, L3 N (wire 4) and PE respectively</li> </ul>

Warning: if possible do not use plugs !!

### 3.3 Compressor start-up

---

**Content** This section covers important information which you need to observe in order to start up the compressor safely.

---

**General points** Each component of the machine is tested at the factory in continuous operation after the final assembly. The test ensures that the components indicate the data given and operate fault-free. During the initial hours of operation the machine must be watched to determine any possible malfunctions.

---



**Important!**

The respective operating manuals must be read and observed for machines with additional optionally installed components (electronic control, frequency converter, refrigerant dryer).

---

**Preparation**

The following points must be observed and carried out before the first start-up:



Step	Task to be carried out / Points to be observed:
1	Have an electrician tighten all screw and terminal connections in the control cabinet
2	The motor bearings of compressors, without permanent greased motor bearings, that are unused longer than 6 month have to be regreased before putting into operation
3	A clearly visible sign must be affixed to machines with remote control with the following wording: <b>Warning! This machine is remote controlled and may start without warning!</b>  When controlling the machine remotely you must take the safety precautions which prevent the machine from starting up while it is controlled or maintained; place a relevant instruction on the remote control switch
4	Do not use the emergency or main switch to switch the machine off during normal operations see chapter 4 "Normal Mode Operation" (Pages 4-5)

---

### 3.3 Compressor start-up (continuation)

#### Checking the rotational direction INFO

When first starting up the machine, as well as after each change to the electrical feed line, the rotation of the screw compressor must be checked.  
The rotation of the V-belt pulley must follow the direction of the attached arrows! If necessary, reconnect the connecting cable (electrician).



#### WARNING!

The rotation control must be carried out as a two-hand operation!

An incorrect rotation for longer than 2 seconds will lead to faults in the screw compressor!



There is a danger from moving parts when checking the rotation with the safety doors open!

Proceed as follows when checking the rotation:

Step	Operation:	Figure / Expl.
1	Open the front door	
2	Start the compressor by tapping the green start button once with the one hand; immediately let go of the button	
3	Within 2 seconds stop the compressor by pressing the red stop button with the other hand.	

### 3.3 Compressor start-up (continuation)

**Test run  
 INFO**

Carry out a test run so that the oil can be distributed throughout the machine.

**Conduct a  
 test run**

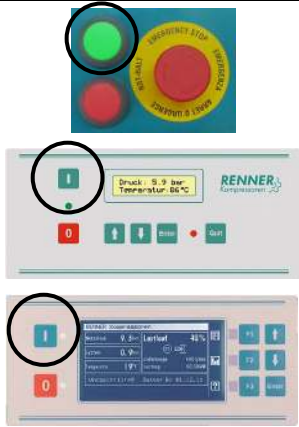
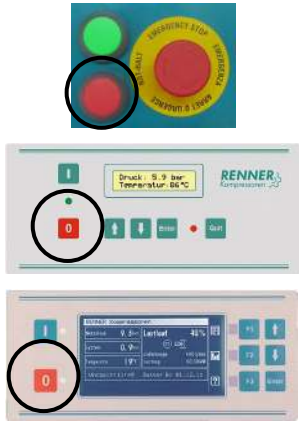
Step	Operation:	Figure / Expl.
1	Open the shut-off valve. Press the start button and let the machine run for approx. 5 seconds.	
2	Press the stop button.	
3	Repeat points 1 and 2 twice.	

# Chapter 4

## Operation / Normal use

---

**Content** This chapter covers the information required for normal operation of the compressor.

---

**Overview** This chapter is subdivided into the following sections:

No.	Subject	Page
4.1	Control instrumentation RENNERlogic	4-2
4.2	Control instrumentation RENNERtronic	4-3
4.3	Control instrumentation RENNERtronic plus	4-5
4.4	Starting normal operation	4-6
4.5	Switching off the compressor	4-8
4.6	Remedying malfunctions in normal operation	4-10

---

## 4.1 Control instrumentation RENNERlogic

### Content

This section provides an overview of the instrumentation control RENNERlogic.

Figure  
 Instrumentation  
 components  
 RENNERlogic

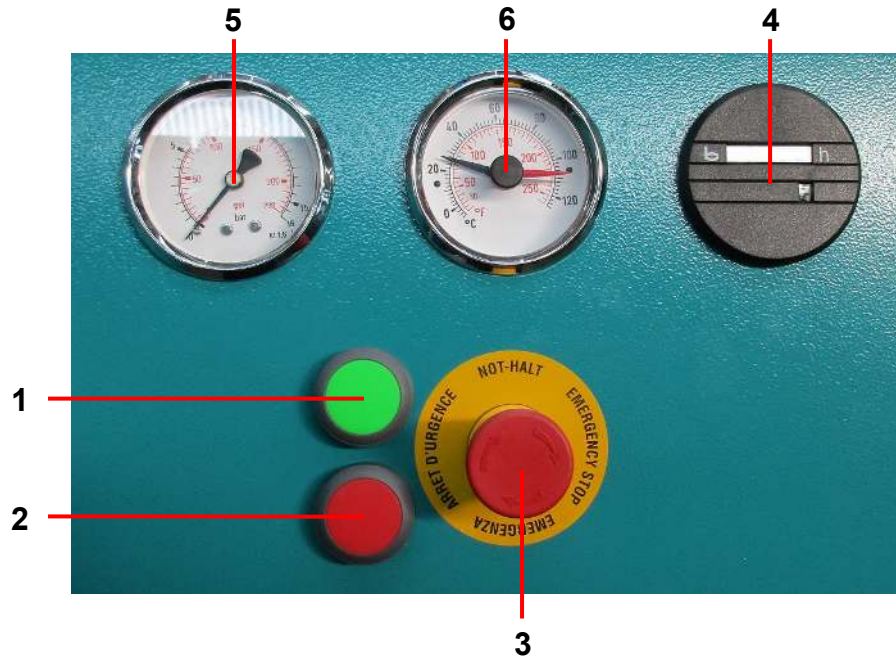

Function  
 Instrumentation  
 components  
 RENNERlogic

The control components have the following function(s):

Item	Description	Function/Use
1	Start button	Starts the compressor  <b>Note:</b> The main switch must be switched on. The main switch is installed by the customer.
2	Stop button	Stops the compressor
3	Emergency Stop	Stops compressor immediately in emergency
4	Operating hour meter	Counts the number of hours the compressor has actually run
5	Pressure gauge <i>Working pressure</i>	Displays working pressure setting
6	Temperature display <i>Combistat</i>	Displays the oil temperature and operating temperature



## 4.2 Control instrumentation RENNERtronic

### Content

This section provides an overview of the instrumentation control RENNERtronic.

Figure  
Instrumentation  
control  
RENNERtronic

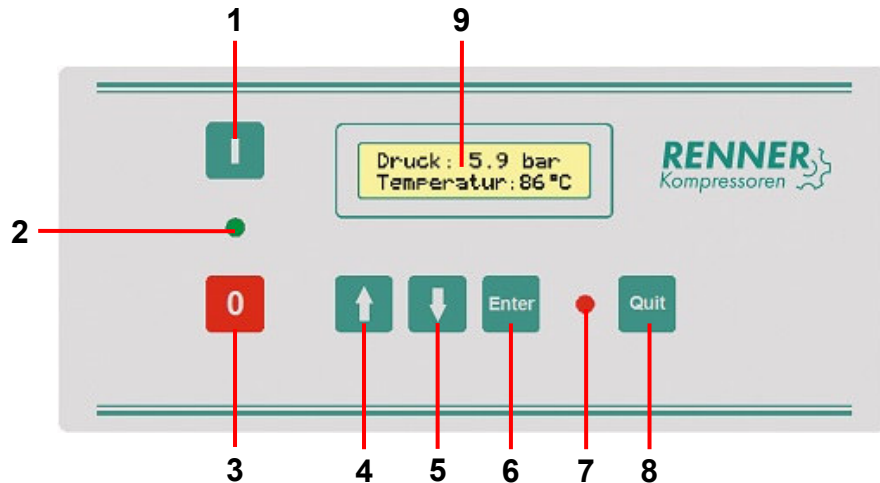

Function  
Instrumentation  
control  
RENNERtronic

The instrumentation control has the following function(s):

Item	Description	Function
1	<b>Compressor ON / Start</b>	Switches the compressor on
2	<b>LED (green)</b>	Service LED
3	<b>Compressor OFF/ Stop</b>	Switches the compressor off
4	<b>Arrow key UP</b>	The UP key takes you to the previous menu item and increases parameter values. Also serves to call up the INFO level (in conjunction with the Enter key)
5	<b>Arrow key DOWN</b>	The DOWN key takes you to the next menu item and decreases parameter values. Also serves to call up the INFO level (in conjunction with the Enter key)

Item	Description	Function
6	Enter	Select a menu item. Confirm or save entries or changes.
7	LED (red)	Fault / maintenance LED
8	Quit	Quit discards inputs and ends a selected menu item. It also acknowledges warning and error messages.
9	Display	Displays the parameters and the error/warning messages. <b>1st line:</b> Displays current operational data <b>2nd line:</b> Displays menu values as well as error and warning messages.

---

### 4.3 Control instrumentation RENNERtronic plus

**Inhalt**

This section provides an overview of the instrumentation control RENNERtronic plus.

**Figure**  
Instrumentation control  
RENNERtronic plus

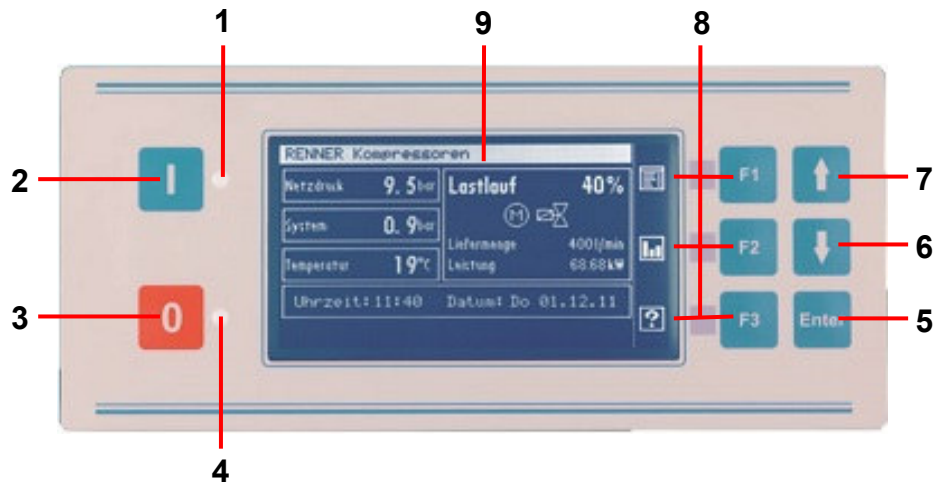

**Function**  
Instrumentation control  
RENNERtronic plus

The instrumentation control has the following function(s):

Pos.	Bezeichnung	Funktion
1	LED (green)	Service LED
2	Compressor ON / Start	Switches the compressor on
3	Compressor OFF/ Stop	Switches the compressor off
4	LED (red)	Fault / maintenance LED
5	Enter	Select a menu item. Confirm or save entries or changes.
6	Arrow key DOWN	The DOWN key takes you to the next menu item and decreases parameter values.
7	Arrow key UP	The UP key takes you to the previous menu item and increases parameter values.
8	Function keys F1, F2, F3	On the display (9) to the left of the function keys, there is always the current assignment
9	Display	Displays the parameters and the error/warning messages.

## 4.4 Starting normal operation

### Content

The following section explains how to start the compressor and contains essential points for normal operation.



### Danger!

There are moving parts inside the compressor housing which can cause serious injuries.

Never operate the compressor with the housing open!

### Before starting the compressor

Check the following points before starting the compressor:

- Is the oil level sufficiently high?
- Is the main switch on?
- Are any existing shut-off valves open?

### Start compressor and monitor in normal operation

Step	Operation	Figure / Expl.
1	Press the <i>Start</i> button to start the compressor.	
2	Monitor the following points at regular intervals during operation:	
2a	<b>Working pressure</b> The working pressure displayed must not exceed the maximum permissible value specified on the type plate. If this is the case, switch off the compressor immediately.	

## 4.4 Starting normal operation (continuation)

Monitor normal operation (contd.)

Step	Operation	Figure / Expl.
2b	<p><b>Oil temperature and operating temperature</b>            The oil temperature and operating temperature must not exceed 110°C. If 110°C is exceeded the compressor will cut out automatically.</p> <p><b>Important!</b>            Should the compressor fail to cut out automatically it must be switched off immediately by hand!</p>	
2c	<p><b>Operating hour meter</b>            Various maintenance work must be carried out after a specified number of operating hours. The exact maintenance intervals and relevant servicing work are listed in the maintenance schedule.</p>	



## 4.5 Switching off the compressor

### Content

This section explains how to switch off the compressor in normal operation and/or at the end of operations.

### Stop normal operation

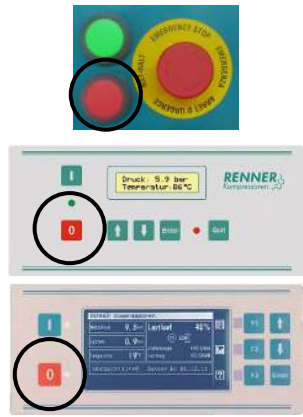
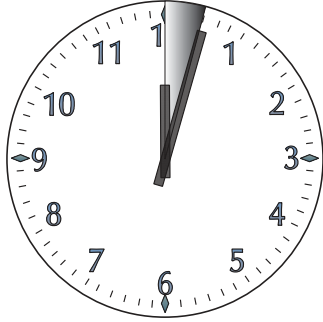
To switch off the compressor carry out the steps below in the order listed:

Step	Operation	Figure / Expl.
1	Press the red <i>Stop</i> button while the compressor is running to shut down the compressor.	
3	<p>The compressor now switches to the follow-on time and stops automatically after that.</p> <p><b>NB!</b>                      The follow-on time must not be shorter than the pre-adjusted time! (A longer period of time is no problem).</p>	
4	Press the Emergency Stop to secure the compressor <i>Emergency Stop</i>	

## 4.5 Switching off the compressor (continuation)

---

**Completely shut off** If you want to shut off the compressor completely: (e.g. after completing the work), then in addition to the above steps, you must also turn off the main switch.

---



**Note:**

Switching the machine off via the red emergency stop button can lead to the oil frothing up in the separator tank. Possible consequences:

- Exit of oil exit with the discharge air.
- Oil overflow in the separator cartridge
- The compressed air could contain oil when re-starting the machine.

Although this is not usually critical and is normalised during operations, in certain cases, it could however become necessary to replace the separator cartridge.

## 4.6 Remedying malfunctions in normal operation

---

### Content

This section contains advice on remedying malfunctions.

---



### Danger!

Human error in remedying faults or lack of professional training can lead to serious damage to property or physical injury. It is therefore essential that faults are rectified by duly qualified persons.

---

### Before removing faults

Always take the following steps before starting any work:

- Switch the compressor and main switch off!
  - Discharge all the compressed air from the compressor and air vessel!
- 

### Malfunctions

The following faults may occur during operation:

Fault	Possible Cause	Remedy
System starts starting	<ul style="list-style-type: none"> <li>● No power</li> <li>● Loose cables or fuses</li> <li>● Motor protection switch has cut out</li> <li>● Combistat cut out / defective</li> <li>● Connecting lines to Combistat are kinked</li> </ul>	<ul style="list-style-type: none"> <li>➤ Establish power supply</li> <li>➤ Retighten cables or fuses</li> <li>➤ Unlock motor protection switch (switch cabinet)</li> <li>➤ Ensure correct cooling; install new Combistat if defective</li> <li>➤ Ensure correct guiding of connection cables</li> </ul>

*Continued overleaf*



## 4.6 Remediating malfunctions in normal operation (continuation)

### Malfunctions (contd.)

Fault	Possible Cause	Remedy
System starts with difficulty	<ul style="list-style-type: none"> <li>• Time for star-delta connection too long or too short</li> <li>• Machine is under compression load</li> <li>• Voltage fluctuations in the grid</li> <li>• Ambient temperature too low causing excess viscosity of oil</li> <li>• Oil is too viscous</li> </ul>	<ul style="list-style-type: none"> <li>➤ Check and correct time setting, correct setting 3-6 seconds, adjust on Relay K 1T</li> <li>➤ Determine reason</li> <li>➤ Check solenoid valve and relief valve and change if necessary</li> <li>➤ Heat installation location</li> <li>➤ Select correct type of oil: RENNER VDL N ISO 68 or 46 for low temperatures.</li> </ul>
Compressor cuts out before reaching discharge pressure	<ul style="list-style-type: none"> <li>• Motor overload tripping</li> <li>• Combistat cuts out due to excessively high temperature</li> <li>• Short circuit in trip line</li> </ul>	<ul style="list-style-type: none"> <li>➤ Check and adjust overload setting; check and adjust discharge pressure switch setting; check supply lead for phase failure.</li> <li>➤ Ensure correct cooling; install new Combistat if defective</li> <li>➤ Eliminate cause of short circuit, change defective fuse</li> </ul>

*Continued overleaf*

## 4.6 Remediating malfunctions in normal operation (continuation)

**Malfunctions  
 (contd.)**

Fault	Possible Cause	Remedy
Motor overload tripping (therm. overcurrent relay) has stopped the system	<ul style="list-style-type: none"> <li>• Blocked system</li> <li>• Phase failure</li> <li>• Motor over-loaded</li>   <li>• Ambient temperature too high</li> </ul>	<ul style="list-style-type: none"> <li>➤ Eliminate reason for seizure</li> <li>➤ Check supply line</li> <li>➤ Check and adjust overload setting; check and adjust discharge pressure switch setting</li>   <li>➤ Ensure adequate ventilation</li> </ul>
Combistat cuts out due to excessively high temperature	<ul style="list-style-type: none"> <li>• Insufficient oil</li>   <li>• Oil filter clogged</li> <li>• Oil thermostat defective</li> <li>• Oil cooler dirty</li> <li>• Compressor incorrectly installed</li>   <li>• Combistat defective or incorrectly set</li> </ul>	<ul style="list-style-type: none"> <li>➤ Check and adjust oil level</li>   <li>➤ Change oil filter</li> <li>➤ Replace oil thermostat</li> <li>➤ Clean oil cooler (air or oil side)</li> <li>➤ Refer to recommendations for installation</li> <li>➤ Adjust or replace Combistat</li> </ul>
Safety valve blows	<ul style="list-style-type: none"> <li>• Safety valve defective</li> <li>• Oil separator cartridge clogged</li> </ul>	<ul style="list-style-type: none"> <li>➤ Change safety valve</li>   <li>➤ Change separator cartridge</li> </ul>

*Continued overleaf*

## 4.6 Remediating malfunctions in normal operation (continuation)

**Malfunctions  
(contd.)**

Fault	Possible Cause	Remedy
Oil in compressed air	<ul style="list-style-type: none"> <li>• Oil scavenge line and nozzle in oil sight glass clogged</li> <li>• Separator cartridge defective</li> <li>• Oil tank level too high</li>   <li>• Compressor was stopped before end of run-on time</li> </ul>	<ul style="list-style-type: none"> <li>➤ Have oil scavenge system cleaned</li>   <li>➤ Check cartridge and replace if necessary</li> <li>➤ Rectify oil level</li>   <li>➤ Never switch off compressor until run-on time has elapsed</li> </ul>
Compressor does not vent during continuous operation; compressor does not cut out during intermittent operation, i.e. safety valve blows	<ul style="list-style-type: none"> <li>• Upper trigger point of discharge pressure switch set too high</li> <li>• Solenoid valve defective</li> <li>• Relief valve defective</li> <li>• Minimum pressure valve jamming</li> </ul>	<ul style="list-style-type: none"> <li>➤ Reset discharge pressure switch</li>   <li>➤ Change solenoid valve</li> <li>➤ Change relief valve</li>   <li>➤ Check and adjust minimum pressure valve</li> </ul>
Compressor vents continuously; low volumetric capacity	<ul style="list-style-type: none"> <li>• Solenoid valve defective</li> <li>• Relief valve defective</li> <li>• Electric supply to solenoid valve disconnected</li> <li>• Auxiliary contact on Y-contactor defective</li> </ul>	<ul style="list-style-type: none"> <li>➤ Change solenoid valve</li> <li>➤ Change relief valve in intake regulator</li> <li>➤ Restore supply line connection</li>   <li>➤ Check switch and replace if necessary</li> </ul>
Non-existent or insufficient discharge capacity	<ul style="list-style-type: none"> <li>• Intake filter clogged</li> <li>• Intake regulator or intake valve jamming or positioned incorrectly (continuous operation)</li> <li>• Leaks in the system</li> </ul>	<ul style="list-style-type: none"> <li>➤ Change air filter</li>   <li>➤ Check regulator and butterfly valve and clean bearing and guides</li>   <li>➤ Rectify leaks</li> </ul>

Continued overleaf

## 4.6 Remediating malfunctions in normal operation (continuation)

**Malfunctions  
 (contd.)**

Fault	Possible Cause	Remedy
Intake regulator does not close at discharge pressure	<ul style="list-style-type: none"> <li>• Actuating cylinder defective, no control pressure</li> <li>• Nozzle blocked or frozen</li> </ul>	<ul style="list-style-type: none"> <li>➤ Install new actuating cylinder, check solenoid valve</li> <li>➤ Clean nozzle</li> </ul>
Pressure vessel not depressurising	<ul style="list-style-type: none"> <li>• Non-return valve defective</li> </ul>	<ul style="list-style-type: none"> <li>➤ Change non-return valve</li> </ul>
Oil in compressor, oil mist on venting	<ul style="list-style-type: none"> <li>• Loose connection in oil line</li> <li>• Check seal on oil drain plug</li> <li>• Machine is shut off if under load (e.g. emergency stop switch)</li> <li>• Check condition and fit of O-ring on intake regulator</li> </ul>	<ul style="list-style-type: none"> <li>➤ Tighten connection</li> <li>➤ Tighten screw, seal if necessary</li> <li>➤ Do not switch compressor off until it has coasted for three minutes, or check the minimum run-on time and set to three minutes</li> <li>➤ Fit new O-ring if necessary</li> </ul>
System runs noisily	<ul style="list-style-type: none"> <li>• V-belts not correctly tensioned</li> <li>• V-belt sets not compatible</li> <li>• V-belt pulleys not aligned with each other</li> </ul>	<ul style="list-style-type: none"> <li>➤ Check V-belt tension and tighten if necessary</li> <li>➤ Replace with matching set of belts</li> <li>➤ Check alignment of pulleys and adjust if necessary</li> </ul>

# Chapter 5

## Maintenance instructions

---

**Content** This chapter contains information on the maintenance work required.

---

**Overview** This chapter is subdivided as follows:

No.	Subject	Page
5.1	What to take into account	5-2
5.2	Remove faults	5-5
5.3	Venting the compressor system	5-6
5.4	Cleaning work	5-7
5.5	Checking oil level	5-8
5.6	Changing oil filter	5-9
5.7	Changing oil	5-10
5.8	Cleaning oil level sight glass	5-11
5.9	Cleaning oil cooler	5-11
5.10	Check safety valve	5-12
5.11	Tensioning and changing the drive belt(s)	5-13

---

## 5.1 What to take into account

---

**Content** This section contains general information to be heeded during servicing and maintenance work.

---

**Personnel requirement** Servicing and maintenance work may only be carried out by duly qualified personnel.

The specific personnel requirements are set out in Chapter 0.

---



### Danger!

It is essential to adhere to the following safety instructions in order to avoid all risks of personal injury or death:

Potential Source of Danger	Preventive Measures
Crushing from moving parts	<ul style="list-style-type: none"> <li>● Always maintain a safe distance from all moving parts when carrying out test runs</li> </ul>
Electric shock	<ul style="list-style-type: none"> <li>● Switch off all voltage sources before starting work.</li> <li>● Take measures to prevent power sources from being switched on again by accident</li> </ul>
Inappropriate spare parts	<ul style="list-style-type: none"> <li>● Always replace self-locking nuts and screws</li> <li>● Only use spare parts included in the approved lists</li> </ul>
Unauthorised/premature approval of unit for operation	<ul style="list-style-type: none"> <li>● Do not release the unit for operation until the safety devices are fully functional.  <b>Only then is the work completed!</b></li> </ul>

---

## 5.1 What to take into account (continued)

---

**After completion of work**

The following steps must be carried out after completing the work:

Step	Operation
1	Follow the maintenance schedule and complete the inspection sheets, activity logs, etc. (see Appendix W "Maintenance Check").
2	Check that the safety devices are working correctly. Do not release the machine for operation if the safety devices are not in perfect working order.
3	Reinstall and secure any safety devices that have been removed.
4	Remove any tools, foreign objects and materials left lying around.
5	Carry out a test run and check the function of the serviced components.
6	If you leave the machine before completing the work keep the keys safe and inaccessible to unauthorised persons.

---

**Spare parts, accessories**

Only genuine spare parts should be used when replacing components such as the oil filter, oil, air filter, separator cartridge, V-belt, etc.

---

**Repairs**

Only allow authorised dealers to carry out repair work. A list of other persons authorised by the manufacturer to carry out repairs can be obtained from the manufacturer on request.

**Do not allow repairs to be carried out by any persons other than those authorised by the manufacturer!**

Servicing is carried out as agreed with the authorised dealer.

---

## **5.1 What to take into account (continued)**

---

### **General Notes**

Take the standard safety precautions and proceed with great care when carrying out any servicing work.  
Please follow especially the points below:

- Servicing work to be carried out by qualified personnel only.
  - Correct tools only to be used for servicing work.
  - Unit and power supply to be switched off before any servicing work is carried out. Take measures to ensure that the unit cannot be switched on accidentally!
  - Unit must be allowed to cool before carrying out servicing work to avoid risk of burns!  
Exception: oil change (unit at operating temperature); safety instructions to be strictly adhered to in this case!
  - Unit to be disconnected from all sources of pressure and all pressure removed before executing a maintenance work or dismantling pressurised parts.
  - Scrupulous standards of cleanliness to be maintained during servicing work; parts and exposed openings to be covered with a clean cloth, paper or masking tape.
  - Motor, air filter, electrical components, control equipment, etc. to be protected from ingress of moisture, e.g. when being wiped.
  - Welding or other heat-based work never to be carried out in close proximity to the oil system; oil tank to be fully discharged and cleaned before such work.
  - No tools, loose parts or rags to be left in or on the unit.
  - Operating pressures, temperatures, time settings, control equipment and cut-out devices to be checked for perfect working order before unit is released for operation after maintenance work.
  - Doors on unit to be closed before switching on the unit (including for test run)!
  - Sound-absorbing materials to be left in place and retained.
-



## 5.2 Remove faults

---

### Content

This section covers general points on troubleshooting and contains references to relevant sources of information.

---



### Danger!

- Always take measures to ensure that the machine can be shut off in an emergency by a second person.
  - You may only rectify faults or carry out checks if you are duly qualified (specialist training in mechanical or electrical engineering).
  - Adhere to the general safety instructions contained in this manual for handling the machine.
  - Follow the instructions given in this chapter and all other maintenance instructions issued by the operator and pay due regard to the documentation relating to the components included in the unit (e.g. frequency converter, refrigerant dryer).
- 

### List of faults

The necessary action to be taken in the event of faults is outlined...

... in Chapter 4.4. "Remedying malfunctions in normal operation" and

... in the operator's internal servicing documents.

---

## 5.3 Venting the compressor system

---

### Contents

This section outlines the main points to be taken into account when the unit has to be vented.

---

### Why vent?

The pressure has to be removed from the unit before all servicing and maintenance work. The unit vents automatically when switched off but if there is a fault the unit might remain pressurised even after being switched off. Since this is not evident from the outside it is always essential to vent the unit before servicing work.

---



**Beware of burns when unit is at operating temperature! The oil filler plug can reach temperatures up to approx. 110 °C ! Always use gloves when handling the oil filler plug!**  
**When the oil filler plug is unscrewed the residual pressure may cause hot oil to squirt out! It is therefore essential to wear safety goggles!**

---

### Venting the compressor system

It is essential to adhere to the following instructions in order to avoid the above risks of personal injury or death:

Step	Operation
1	Switch off the unit and take measures to prevent it from being restarted.
2	Unscrew cap on filler neck (oil filler plug) by hand.
3	The first five rotations of this plug must be made slowly in an anti-clockwise direction until the detectable "snap point" is reached; the oil filler plug has a side safety borehole through which the residual pressure can gradually discharge.
4	Wait until all the pressure in the unit has been relieved; the unit is now depressurised.

---

## 5.4 Cleaning work

---

### Content

The following section contains information on cleaning the compressor and the air filter.

---

### General points

In terms of general cleaning, vacuum the unit or wipe it with a damp cloth. Check the intake passage regularly, where necessary removing any leaves, dust, dirt or similar matter in the interests of an efficient air supply.

---



**Never direct compressed air at living beings!**  
**Misuse of the compressed air unit can cause serious tissue damage or even fatal injuries.**

---

### Cleaning the air filter

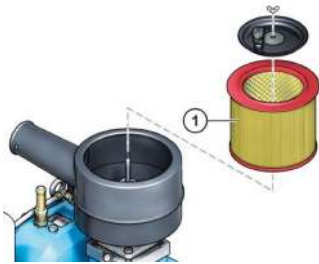

Step	Operation
1	Switch off the unit and take measures to prevent it from being restarted.
2	Unscrew filter cover and remove filter cover.
3	Remove filter cartridge.
4	Wipe dust out of filter housing with a slightly damp cloth.
5	Replace filter.
6	Insert filter in housing.
7	Fit filter cover and screw on, ensuring that the cover is correctly seated.
8	Carry out test run and functional check.

---

## 5.5 Checking oil level

### Content

This section outlines the procedure for checking the oil level in the compressor.

### General points

The level in the oil tank is a key factor in the operational safety of the unit. Due diligence should be exercised in conducting the following checks at the specified times. Otherwise we cannot accept liability in the event of damage.



**Follow the safety instructions for venting the unit (see Chap. 5.3)**

### Checking the oil level

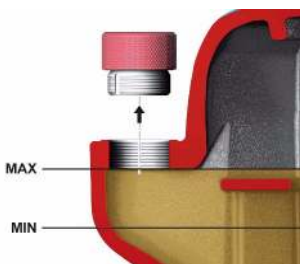
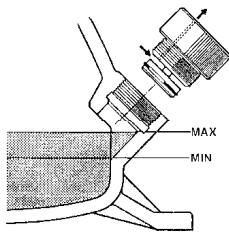

Step	Instructions
1	Switch off the unit and take measures to prevent it from being restarted.
2	Wait until the unit has been switched off for at least three minutes.
3	Unscrew cap on filler neck of block by hand.
4	To check the oil level, look on the oil sight glasses: <u>Minimum oil level:</u> Oil must not fall below half of the oil sight glass <b>right next to</b> the thermal valve <u>Maximum oil level:</u> Oil should not be higher than half of the oil sight glass <b>over</b> the thermal valve
5	If necessary, refill to the maximum mark with oil of the same kind.
6	Replace the oil filler plug firmly by hand.
7	Switch on the unit and check for leaks at the oil filler neck.
8	If necessary, change the O-ring at the filler neck.

## 5.6 Changing oil filter

---

**Content** This section outlines the procedure for changing the oil filter.

---

**Important note!** An oil filter may only be changed when the unit is switched off and fully depressurised and without power.

---

### Changing the oil filter

Step	Operation
1	Switch off the unit and take measures to prevent it from being restarted. Allow the unit to cool to approx. 70°C and then remove the pressure as described in Chapter 5.3.
2	Loosen the old oil filter with the hexagon screw and remove it.
3	Place the new oil filter in the air end and tighten it.
4	Start the unit and check the oil filter for leaks.
5	Record the oil filter change on the maintenance check sheet.

---



**Comply with environmental guidelines  
when disposing of used filter cartridges!**

---

## 5.7 Changing oil

### Content

This section outlines the procedure for changing the oil.

### Important note!



The oil may only be changed when the unit is switched off and fully depressurised! The unit should be at operating temperature (approx. 60°C - 80°C) when the oil change is carried out. The unit should be run with the type of oil best suited to its operation. The oil used by the factory is RENNER VDL N ISO 68. It is recommended that this grade of oil is used. Other oil grades must be comparable to the RENNER VDL ISO 68. Only refill the unit with oil of the same make and the same grade.

**Do not mix oils of different kinds!**

**Follow the safety instructions for venting the unit (see Chap. 5.3)!**

### Changing the oil

Step	Operation
1	Switch off the unit and take measures to prevent it from being restarted. Allow the unit to cool to approx. 70°C and then remove the pressure as described in Chapter 5.3.
2	Take a receptacle suitable for collecting the oil and position it under the ball valve on the base of the compressor block and then unscrew the plug and open the ball valve.
3	Drain all the oil from the compressor block then close the ball valve and replace the plug.
4	Pour the new oil into the filler neck up to the maximum level and replace the oil filler plug firmly by hand.
5	Switch the unit on, let it run 2 to 3 times for only about 5 seconds and switch it off again. This allows the oil to be distributed in the unit before it is put on load.
6	Switch the unit on and allow it to run for approx. three minutes.
7	Check the oil level and, if necessary, refill to maximum mark.
8	Check drain plug and oil filler plug for leaks.
9	Record the oil change on the maintenance check sheet.



### Comply with environmental guidelines when disposing of used oil!

\* The machine must be completely emptied before using a synthetic oil, e.g. (RENNER Super Lub). (Including cooler and filter)

## 5.8 Cleaning oil return window

---

**Content** This section outlines the procedure for cleaning the oil scavenge sight gauge (optional extra).

---

**General points** The oil scavenge sight gauge is screwed onto the line on the separator cartridge.

---

### Cleaning the oil level indicator

Step	Operation
1	Switch off the unit and take measures to prevent it from being restarted. Allow the unit to cool to approx. 70°C and then remove the pressure as described in Chapter 5.3.
2	Undo the screws on the oil scavenge sight gauge.
3	Remove sight gauge and wipe over with a cloth.
4	Check seal and replace if necessary.
5	Refit sight gauge.

---

## 5.9 Cleaning oil cooler

---

**Content** This section outlines the procedure for cleaning the oil cooler.

---

**General points** If the oil cooler is not very dirty it can be left in the unit and blown with compressed air while the unit is switched off. If the oil cooler is very dirty proceed as outlined below.

---

### Cleaning the oil cooler

Step	Operation
1	Switch off the unit and take measures to prevent it from being restarted. Allow the unit to cool to approx. 70°C, disconnect from the power supply, and remove the pressure as described in Chapter 5.3.
2	Remove the oil cooler.
3	Steam clean the oil cooler.
4	Refit oil cooler.
5	Start the unit and check for leaks.

---

## 5.10 Check the safety valve

---

### Check

After 2000 operating hours - however at least 1x a year

---

### General points

The check process may only take a few seconds and be completed only by hand

---



#### Caution risk of injury!

Scalding danger by escaping hot air-oil mixture  
Since this is a dangerous process, please proceed with extreme caution.

Additionally, safety precautions should be taken, such as safety goggles and ear protection.

---

### Check the safety valve



Step	Operation
1	Unscrew the cap (1) by turning counterclockwise (do not use any tools!)
2	The cap must lift and let out air.
3	Close the cap by turning clockwise.
4	After closing the cap, no more air should escape.



**The average service life of the valve seal is 3 years!**

---



## 5.11 Tensioning and changing of drive belts(s)

**Content** This section outlines the procedure for tensioning and/or changing the V-belt.

**General points** The belt can be set to the optimum tension using the adjustmentscrews on the air end block.

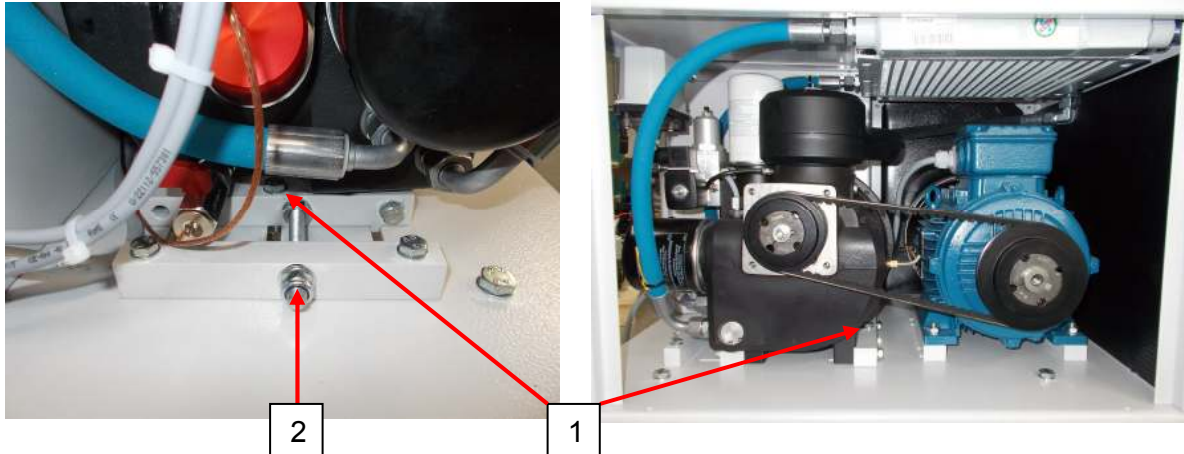

Fig. Tighten drive belt



**The optimum capacity of the system and service life of the V-belt is guaranteed only if the belt is correctly tensioned. Please check the setting before start up and after 100 operating hours, as well as according to the information in the maintenance plan.**

For replacing or re-tensioning the V-belt, please proceed as follows:

### Tighten drive belt

Step	Operation
1	Switch off the unit, disconnect it from the power supply, and take measures to prevent it from being re-started.
2	Loosen the air end screws.(1)
3	Turn the adjustment screw (2) (in a clockwise direction) until the optimum tension is reached.
4	Tighten the screws on the air end again.
5	The correct pre-tensioning value can be obtained from the data sheet.
6	Using a pre-tensioning test device (e.g. <b>optibelt</b> Optikrik) you can review the values

**Change the  
V-belt**

Step	Operation
1	How to "tighten a V-belt", step 1 and 2
2	Loosen adjustment screw, remove old belts
3	Insert the new V-belt (please only use RENNER original spare parts).
4	As described above in "Tighten belts", step 3 – 6.



**Check for each V-belt replacement the alignment of the V-belt pulleys to each other.**

**Please note that the correct V-belt tensioning values and the alignment of the pulleys are a deciding feature for the service life of the V-belt.**

# Chapter 6

## Decommissioning and disposal

---

**Content** This chapter contains important advice for (temporarily) decommissioning or disposing of your compressor.

---

**Survey** This chapter is divided into the following sub-sections:

No.	Subject	Page
6.1	Decommissioning of plant	6-2
6.2	Re-commissioning after storage	6-3
6.3	Shut-down and disposal	6-4

---

## 6.1 Decommissioning of plant

---

### Content

This section contains instructions you need to follow when decommissioning the compressor for an extended period of time, and when subsequently returning it to operation.

---

When decommissioning for an extended period of time, prepare the unit as follows:

### Decommissioning of plant

Step	Activity
1	A qualified electrician should disconnect the compressor from power supply and lock off isolator to ensure it can not be restarted by accident.
2	Check oil level and fill if necessary (see Chapter 5.5 "Checking oil level") The unit should be stored with its oil tank filled to the max. recommended level
3	Slacken the V-belt (see Chapter 5.11 "Tensioning and changing of belt").
	Do <u>not</u> cover the unit with any material that is impermeable to air. Doing so intensifies the corrosion of individual parts.

---

## 6.2 Re-commissioning after storage

---

### Re-commissioning information

Compressor units that have been switched off, decommissioned or stored away for longer than 3 months, should not be put back into operation until the following measures have been carried out.

---

### Re-commissioning after storage

Follow the procedure outlined below to return the compressor to operation after being out of commission for 3 months or more.

Step	Activity
1	Turn the screw compressor in the direction of rotation several times by hand.
2	Remove the air inlet filter and manifold and pour approx. 0.1 litres of oil ("manufacturer recommended compressor oil only") into the suction port. Then, turn the screw compressor by hand in the direction of the rotation arrow (anti-clockwise) once more.
3	Check the oil level (in the reclaimer tank) and fill where necessary, see 5.5. "Checking of oil level".
4	Connect unit: see Chapter 3.2 "Connections".
5	Re-adjust the V-belt (see Chapter 5.11 "Tensioning and changing of belt").

---

## 6.3 Shut-down and disposal

---

### Content

This section describes what you need to consider when shutting down and disposing of the unit.

---



#### **DANGER**

- Observe the safety instructions outlined in this handbook, the instructions specified in the supplier's documentation as well as accident prevention guidelines.

#### **Danger of life!**

- Moving or lifting the compressor should only be undertaken in a safety conscious manner.
- Always ensure no one is within the danger zone when the compressor is being lifted.

#### **DANGER**

When carrying out the following disassembly work be aware of sharp corners and edges which may cause cuts. For this reason always wear protective gloves.

#### **Environment**



- The following instructions must be observed properly to prevent any possible damage to the environment. The Operating Company must ensure that the regulations are adhered to correctly even where disposal is carried out by an authorized firm of specialists.

### **Disassembly of the compressor**

To dismantle the compressor, proceed as follows and observe the following points:

Step	Activity
1	Find out how each component (or the whole machine) needs to be disposed of. If unsure, consult your local environmental agency.
2	Depressurise all components and vent the unit (see Chapter 5.3. "Venting the plant").

---

### 6.3 Shut-down and disposal (Cont.)

---

**Materials Information**

The following materials were predominately used in the construction of the unit:

Material	Where used
Batteries, NiCad-/Li	<ul style="list-style-type: none"> <li>• Control</li> </ul>
Copper	<ul style="list-style-type: none"> <li>• Cables</li> </ul>
Steel	<ul style="list-style-type: none"> <li>• Machine frame</li> <li>• Side panels and doors</li> <li>• Motor and components</li> </ul>
Plastic, rubber, PVC	<ul style="list-style-type: none"> <li>• Gaskets</li> <li>• Tubes</li> <li>• Cables</li> </ul>
Tin	<ul style="list-style-type: none"> <li>• Boards</li> </ul>
Polyester	<ul style="list-style-type: none"> <li>• Boards</li> </ul>

**Hazardous waste Information**

The following parts, materials and fluids must be disposed of separately:

Denomination	Application
LCD displays <b>Note:</b> LCD displays contain highly poisonous fluids	<ul style="list-style-type: none"> <li>• Display devices</li> </ul>
Electronic scrap	<ul style="list-style-type: none"> <li>• Electrical supply</li> <li>• Controls (SPS etc.)</li> <li>• Boards with electronic parts</li> </ul>



**The environment:**

**Dispose of all parts of the unit in a manner that prevents damage from being caused to other peoples' health or the environment.**

---

## Appendix T: Data sheet

Manual  
RENNER GmbH



Type	Free air delivery		Nominal power	Start	Noise level	Quantity of oil	Cooling air	Outlet connection	HRC Fuse	Electr. Conn.	Dimensions mm	Weight	Air receiver								
	m <sup>3</sup> /min													kW	db(A)	ltr	m <sup>3</sup> /h	Amp	mm <sup>2</sup>	L x B x H	kg
	7,5 bar	10 bar																			
<b>RS-B 2.2</b>	0,335	0,265	2,2	direkt	66	1,95	300	½"	16	2,5	716 x 536 x 540	124	x-500								
<b>RS-B 3.0</b>	0,46	0,38	3,0	direkt	70	1,95	300	½"	16	2,5	716 x 536 x 540	133	x-500								
<b>RS-B 4.0</b>	0,64	0,53	4,0	direkt	70	1,95	340	½"	16	2,5	716 x 536 x 540	133	x-500								
<b>RS-B 5.5</b>	0,83	0,74	5,5	YΔ	75	1,95	560	½"	16	2,5	716 x 536 x 540	159	x-500								
<b>RS-B 7,5</b>	1,13	1,015	7,5	YΔ	78	3,15	980	½"	25	4	776 x 556 x 597	189	x-500								
<b>RS-B 11</b>	1,57	1,54	11,0	YΔ	81	3,15	1950	½"	35	6	776 x 556 x 597	207	x-500								
<b>RSK-B 2.2</b>	0,335	0,265	2,2	direkt	66	1,95	600	½"	16	2,5	971 x 536 x 705	160	x-500								
<b>RSK-B 3.0</b>	0,46	0,38	3,0	direkt	70	1,95	600	½"	16	2,5	971 x 536 x 705	169	x-500								
<b>RSK-B 4.0</b>	0,64	0,53	4,0	direkt	70	1,95	640	½"	16	2,5	971 x 536 x 705	169	x-500								
<b>RSK-B 5.5</b>	0,83	0,74	5,5	YΔ	75	1,95	860	½"	16	2,5	971 x 536 x 705	195	x-500								
<b>RSK-B 7,5</b>	1,13	1,015	7,5	YΔ	78	3,15	1280	½"	25	4	1031 x 556 x 721	225	x-500								
<b>RSK-B 11</b>	1,57	1,54	11,0	YΔ	81	3,15	2250	½"	35	6	1031 x 556 x 721	243	x-500								

RSD-B - Compressor on air receiver

RSDK-B - Compressor and refrigeration dryer on air receiver



## EC Declaration of Conformity according to machine guideline 2006/42/EC Appendix II 1.A

The manufacturer / distributor

RENNER GmbH Kompressoren  
Emil-Weber-Straße 32  
74363 Güglingen

hereby declares that the following product

Product description: **RENNER Screw Compressor**  
Manufacturer: **RENNER**  
Serial no.:  
Series / type description: **RS-B, RSK-B, RSD-B, RSDK-B 2,2 - 11 kW**  
Description:  
Screw Compressor for generating compressed air of 7,5 to 10 bar

meets all relevant provisions of the above stated guideline and the other applied guidelines (to follow) - including the changes applicable at the time of the declaration.

The following further EU directives were applied:

EMC directive 2014/30/EU  
Directive 2014/29/EU  
RoHS directive 2011/65/EU

The following harmonised standards were applied, in its current version:

EN 1012-1	Compressors and vacuum pumps - Safety requirements - Part 1: Compressors
EN 286-1	Simple unfired pressure vessels designed to contain air or nitrogen - Part 1: Pressure vessels for general purposes
EN 60204-1	Safety of machinery - Electrical equipment of machines - Part 1: General requirements
EN ISO 12100	Safety of machinery - General principles for design - Risk assessment and risk reduction
EN ISO 13849-1	Safety of machinery - Safety relevant parts of controls - Part 1: General principles for design
EN ISO 13849-2	Safety of machinery - Safety relevant parts of controls - Part 2: Validation

Name and address of person who is authorised to compile the technical documentation:

Michael Zottl  
RENNER GmbH Kompressoren  
Emil-Weber-Straße 32  
74363 Güglingen



(Signature)  
Managing Director



(Signature)  
Contractor for documentation

# Appendix W - Maintenance Control

## for RS-B 3 - 11

### with less than 2000 hours / year



Maintenance work	commissi oning	periodi cally	after ... years											
			1	2	3	4	5	6	7	8	9	10		
Fill out commissioning report	✓													
Check screw connections and tighten if necessary	✓													
Check that all connections are firm and tight	✓													
Checking the oil Level	✓	✓												
Check the V-belt tension and wear	✓	✓												
Tighten electric clamps	✓	✓												
Functional check of pressure and temperatur gauges	✓	✓												
Measuring / testing current consumption	✓	✓												
Check ON and OFF settings and adjust if necessary	✓		✓	✓	✓	✓	✓	✓	✓	✓	✓	✓	✓	✓
Check the alignment of the V-belt pulleys		✓												
Check the dirt level of the air filter and the possibly mounted ventilator filter pads		✓												
Compressors with air receiver, empty the condensate water*		✓												
Examine all the hoses to ensure that they are in good working condition		✓												
Check funktion of the condensate drain*		✓												
Check contactors for wear		✓												
Control the oil / air cooler and clean if necessary		✓												
Check the compressor to ensure that it has no leaks		✓												
Check the overall condition of the compressor		✓												
Check air filter element, replace if necessary		✓	✓	✓	✓	✓	✓	✓	✓	✓	✓	✓	✓	✓
Clean / replace the filter mats*		✓	✓	✓	✓	✓	✓	✓	✓	✓	✓	✓	✓	✓
Check / replace the safety valve		✓		✓				✓				✓		
Changing the oil filter			✓	✓	✓	✓	✓	✓	✓	✓	✓	✓	✓	✓
Change the oil			✓	✓	✓	✓	✓	✓	✓	✓	✓	✓	✓	✓
Change the fine separator cartridge			✓	✓	✓	✓	✓	✓	✓	✓	✓	✓	✓	✓
Check the follow-on time (>= 3 min)			✓	✓	✓	✓	✓	✓	✓	✓	✓	✓	✓	✓
Replace thermal valve element			✓			✓					✓			
Change oil suction / recirculation hoses				✓		✓		✓		✓		✓		✓
Change control air hose				✓		✓		✓		✓		✓		✓
Replace solenoid valve				✓		✓		✓		✓		✓		✓
Maintenance set minimum pressure valve				✓						✓				
Change the V-belt					✓			✓				✓		
Replace the O-ring on the oil filler plug						✓				✓				✓
Maintenance condensate drain*						✓				✓				
Servicing kit for the intake regulator								✓						✓
Replace minimum pressure valve completely								✓						
Replace oil hoses*									✓					
Replace pressure switch / pressure sensor										✓				
Replace motor bearings A and B side										✓				
Replace electrical contactors														✓
Maintenance package 1 (see maintenance package List for each compressor)			✓											
Maintenance package 2				✓										
Maintenance package 3					✓									
Maintenance package 4						✓								
Maintenance package 5							✓							
Maintenance package 6								✓						
Maintenance package 7									✓					
Maintenance package 8										✓				
Maintenance package 9											✓			
Maintenance package 10												✓		✓

\* if existing

# Appendix W - Maintenance Control

## for RS-B 3 - 11

with more than 2000 hours / year



Maintenance work	commissi oning	periodi cally	after ... hours																	
			2000	4000	6000	8000	10000	12000	14000	16000	18000	20000								
Fill out Commissioning report	✓																			
Check screw connections and tighten if necessary	✓																			
Check that all connections are firm and tight	✓																			
Checking the oil Level	✓	✓																		
Check the V-belt tension and wear	✓	✓																		
Tighten electric clamps	✓	✓																		
Functional check of pressure and temperatur gauges	✓	✓																		
Measuring / testing current consumption	✓	✓																		
Check ON and OFF settings and adjust if necessary	✓		✓	✓	✓	✓	✓	✓	✓	✓	✓	✓	✓	✓	✓	✓	✓	✓	✓	✓
Check the alignment of the V-belt pulleys		✓																		
Check the dirt level of the air filter and the possibly mounted ventilator filter pads		✓																		
Compressors with air receiver, empty the condensate water*		✓																		
Examine all the hoses to ensure that they are in good working condition		✓																		
Check funktion of the condensate drain*		✓																		
Check contactors for wear		✓																		
Control the oil / air cooler and clean if necessary		✓																		
Check the compressor to ensure that it has no leaks		✓																		
Check the overall condition of the compressor		✓																		
Check air filter element, replace if necessary		✓	✓	✓	✓	✓	✓	✓	✓	✓	✓	✓	✓	✓	✓	✓	✓	✓	✓	✓
Clean / replace the filter mats*		✓	✓	✓	✓	✓	✓	✓	✓	✓	✓	✓	✓	✓	✓	✓	✓	✓	✓	✓
Check / replace the safety valve		✓			✓				✓											
Changing the oil filter			✓	✓	✓	✓	✓	✓	✓	✓	✓	✓	✓	✓	✓	✓	✓	✓	✓	✓
Change the oil			✓	✓	✓	✓	✓	✓	✓	✓	✓	✓	✓	✓	✓	✓	✓	✓	✓	✓
Change the fine separator cartridge			✓	✓	✓	✓	✓	✓	✓	✓	✓	✓	✓	✓	✓	✓	✓	✓	✓	✓
Check the follow-on time (>= 3 min)			✓	✓	✓	✓	✓	✓	✓	✓	✓	✓	✓	✓	✓	✓	✓	✓	✓	✓
Replace the O-ring on the oil filler plug				✓			✓			✓			✓			✓			✓	
Change oil suction / recirculation hoses				✓			✓			✓			✓			✓			✓	
Change control air hose				✓			✓			✓			✓			✓			✓	
Maintenance set minimum pressure valve				✓											✓					
Change the V-belt						✓				✓								✓		
Replace thermal valve element						✓				✓									✓	
Maintenance condensate drain*								✓							✓					
Replace solenoid valve								✓							✓					
Servicing kit for the intake regulator									✓											✓
Replace minimum pressure valve completely									✓											
Replace oil hoses*											✓									
Replace pressure switch / pressure sensor													✓							
Replace motor bearings A and B side													✓							
Replace electrical contactors																				✓
Maintenance package 1 (see maintenance package List for each compressor)			✓																	
Maintenance package 2				✓																
Maintenance package 3					✓															
Maintenance package 4							✓													
Maintenance package 5									✓											
Maintenance package 6											✓									
Maintenance package 7													✓							
Maintenance package 8															✓					
Maintenance package 9																	✓			
Maintenance package 10																			✓	

\* if existing

# Appendix W2

## Maintenance of Motor Bearings

---

### Contents

This Appendix provides an overview of how motor bearings are to be maintained. This description only applies to current systems and may differ to the maintenance required for older motors.

---

### Continuously lubricated motor bearings

Our compressors **up to 37kW** are fitted with motors having closed, continuously lubricated deep-groove ball bearings – theoretical service life is between 15,000 and 30,000 operating hours (oh). If operating conditions are different to that defined in the instruction manual, it is imperative that the maintenance intervals are adjusted to the prevailing circumstances and conditions to ensure reliable operations. Should there be high levels of dirt and dust, frequent switch-ons and high ambient temperatures as well as operations at 60Hz, the maintenance intervals must be adjusted accordingly.

### Description Procedure for replacing bearings

1. Switch off unit and prevent it from being restarted by accident.
2. If applicable, uninstall the motor and remove the ancillary components (fan impeller, frame, fan cover, pulley)
3. Disassemble the bearing cover (center) and bearing shield (outside)
4. Remove the old bearing with a puller (if difficult, carefully warm up the bearing) and remove the old grease
5. Carefully warm up the inner ring of the new bearing
6. Push the new bearing to the stop on the shaft and keep it there briefly
7. Generously grease the new bearing with suitable grease
8. Re-assemble the bearing cover and bearing shield
9. Re-install bearing seal

The type designations of the motor bearings can be found in Table 1.

---

## Appendix W2 Maintenance of Motor Bearings (cont.)

---

### Motor bearings requiring re-lubrication

**Our motors from 45 kW are** fitted with “open” ball bearings. Motors this size and up have re-lubrication devices on the A- and B-sides.

These bearings must be re-lubricated regularly in accordance with the information given in the maintenance check sheet.

Our motors are pre-lubricated from the factory with a polyurea-based high-temperature grease for min. 150°C.

**For instance, SKF LGHP 2 or a polyurea-based equivalent is to be used. Order no.: 10254**

It is imperative that these specifications are adhered to when re-lubricating the motor bearings as mixing different greases can significantly shorten the life of the bearings.

**NB!** If operating conditions are different, it is imperative that the maintenance intervals are adjusted to the local circumstances and conditions to ensure reliable operations. This means that should there be high levels of dirt and dust, frequent switch-ons and high ambient temperatures as well as operations at 60Hz, the maintenance intervals must be shortened.

### Procedure for re-lubrication

**Please carry out the following steps to re-lubricate the motor bearings:**

1. Switch off unit and prevent it from being restarted by accident.
2. Thoroughly clean the grease nipples and surrounds.
3. Remove the cap of the re-lubrication device.
4. Remove the cover of the drainage opening (usually opposite). Excess grease is discharged here.
5. Introduce approx. half of the grease to be used for re-lubrication – it is best to use a grease gun. Then let the motor run for approximately 1 minute.
6. Switch the unit off and introduce the remaining re-lubrication grease.
7. Re-install the cap of the re-lubrication device and the cover of the drainage opening.

### Idleness of motors

If the motors are idle for a longer period of time, the motor shaft should be rotated once a month. Rotate the motor shaft manually for at least 5 rotations and bring to a stop in a different position to the starting position.

If the motors have to be idle for more than 6 months, the motor bearings must be re-lubricated before start-up.

If the motors have to be idle for more than 2 years, the motor bearings must be replaced.

## Appendix W2 Maintenance of Motor Bearings (cont.)

The details of the bearings installed by us and the lubrication quantities to be filled (only for WEG motors) are listed below:

Size	Output (kW)	A-side	B-side	Grease quantity (grams)	Re-lubrication interval
90	1,5 / 2,2	6205 ZZ	6204 ZZ	-	-
112	3,7	6307 ZZ	6206 ZZ	-	-
112	3 / 4 / 5,5	6207 ZZ	6206 ZZ	-	-
132	4 / 4,5 / 5,5 / 7,5 / 9 / 1-11	6308 ZZ	6207 ZZ	-	-
160	11 / 15	6309 C3	6209 Z-C3	-	-
180	18,5 / 22	6311 C3	6211 Z-C3	-	-
200	30 / 37	6312 C3	6212 Z-C3	-	-
225	45	6314 C3	6314 C3	27	5000
250	55	6314 C3	6314 C3	27	5000
280	75 / 85 / 90 / 1-110	6314 C3	6314 C3	27	5000
315	110 / 132 / 160	6314 C3	6314 C3	27	5000

Table 1

Operat. Hours	Airfilter cartridge		Oilfilter cartridge	Oilseparator cartridge			Oilfilling			Drive belt			Motor bearings A + B Side		other service work (take another sheet if required)	Signature and date
	cleaned	replaced	replaced	differential pressure	delta p in bar	replaced	checked	replenished	replaced	checked	retensioned	replaced	regreased	replaced		

Please tick the work which has been done and/or record measured data which confirm by signature .

# Appendix ADS

## End Pressure Switch

---

### Contents



This chapter provides a brief overview of all the pressure switch functions.

---

### Warning!

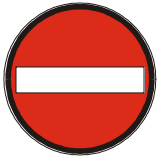

From the factory side, the pressure switch is ideally adjusted to the respective machine configuration. Any change to the default settings can have serious consequences on the service life of your system. The legal warranty will expire if making changes that have not been discussed in advance with RENNER Kompressoren GmbH.

---

### Function

The pressure switch controls the switch-on and switch-off pressure applicable for the respective system. The difference between switch-on and switch-off pressure is generally 1.5 bar. For changes to the switch-off pressure settings made on the factory side, the safety valve is activated if the the permitted maximum pressure is exceeded.

---

*Continued overleaf*



# Appendix ADS End Pressure Switch



Schaltdruck nur unter Druck verändern!  
 Adjust switching pressure only under pressure!  
 Modification de la pression de fonctionnement uniquement sous pression !  
 Modificare la pressione di funzionamento solo sotto pressione!  
 ¡Modificar la presión únicamente bajo presión!  
 Настройку давления включения производить только под давлением!  
 必须在受压的情况下改变压力

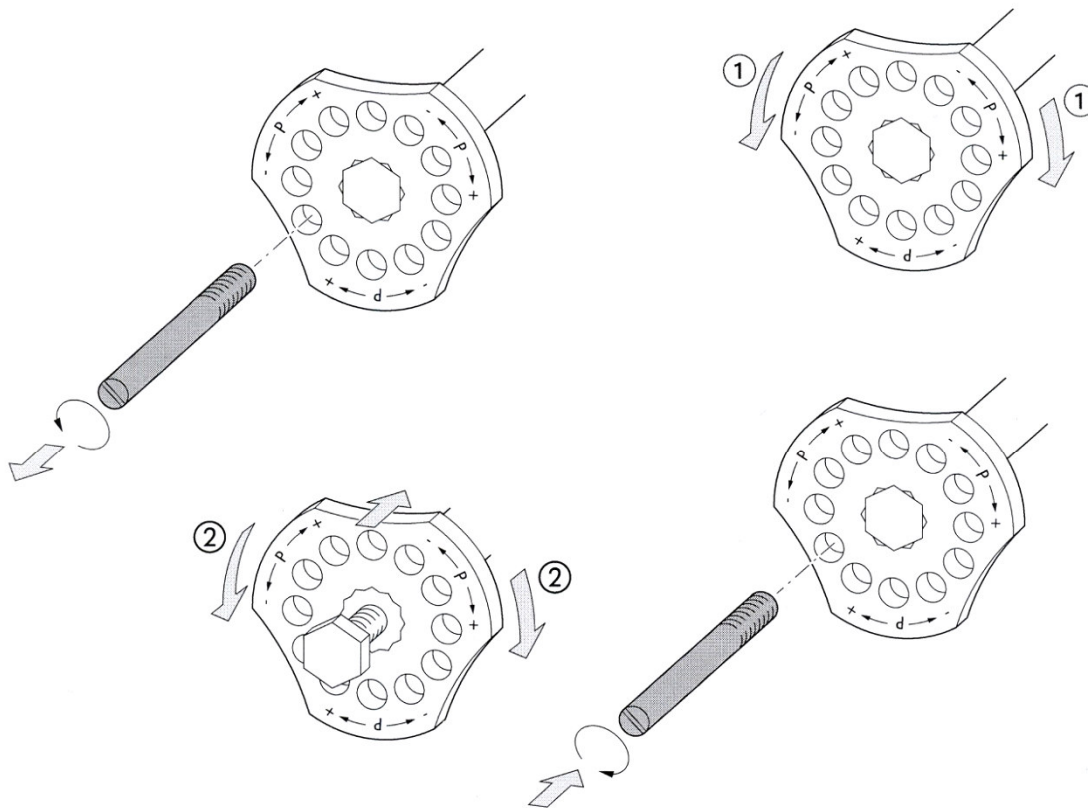

① Pmax. einstellen  
 Pmin. ändert sich mit

② Pmin. einstellen  
 Pmax. ändert sich nicht mit

① Regolare Pmax.  
 Pmin. si modifica

② Regolare Pmin.  
 Pmax. non si modifica

① Set Pmax.  
 Pmin. is altered accordingly

② Set Pmin.  
 Pmax. does not alter

① Ajustar Pmax.  
 Pmin. se modifica

② Ajustar Pmin.  
 Pmax. non se modifica

① Régler Pmax.  
 Pmin. se modifie

② Régler Pmin.  
 Pmax. ne se modifie pas

① Установить Pmax Pmin  
 изменяется также

② Установить Pmin Pmax не  
 изменяется

① Pmax.  
 Pmin.

② Pmin.  
 Pmax.

① 调整  
 改变按

② 调整  
 改变 不按

# Appendix KT

## Operating instructions for the refrigerant drier

---

### Content

In this chapter you receive a brief overview for the optionally installed refrigerant drier.

---

Please follow the refrigerant drier safety instructions found in the separate operating manual. It is particularly dangerous to breath-in the cooling steam or get in contact with the cooling agents. Smoking when working on the refrigerant drier is prohibited, since the cooling agent will developpoisonous vapours when getting in touch with the glowing end of a cigarette or other open flame (e.g. welding work).

---

### Function

The refrigerant air drier contains a cooling system for cooling the compressed air. The compressed air is also de-humidified. The condensate created here is discharged through a condensate separator.

---



Make sure that the air inlet and outlet is never impaired or blocked. Adequate distance must be maintained between the ventilation grids and room walls. Please follow the figure in Chapter 2.3 and the information in Chapter 2.3.1 of the Operating Manual of the refrigerant drier supplier.

---

After turning on the refrigerant drier, wait 5 minutes until the pressure has equalised. Only then, start the compressor.

**Appendix KT refrigerant drier (cont.)**

---

**Figure**  
**Refrigerant drier**

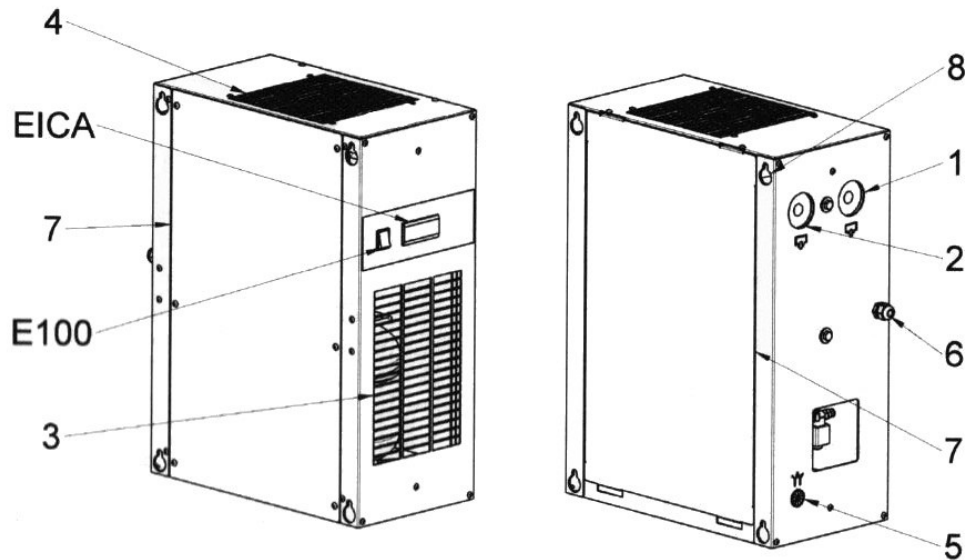

- 1.) Compressed air inlet
- 2.) Compressed air outlet
- 3.) Cooling air inlet
- 4.) Cooling air outlet
- 5.) Steam trap

- 6.) Electrical connections
- 7.) Maintenance access
- 8.) Fixing holes
- E100.) Switch-on
- EICA.) Electronic regulator

**Figure**  
**control panel**

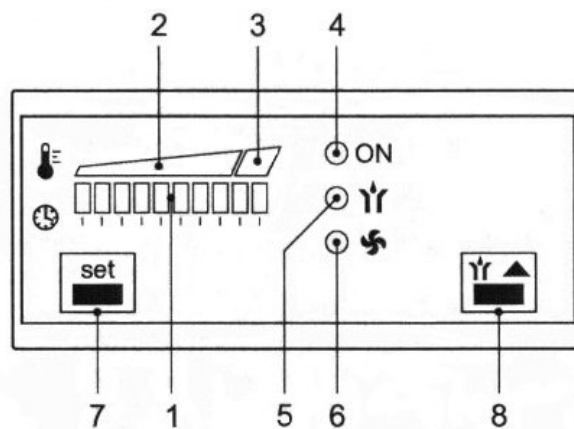

## Appendix KT refrigerant drier (cont.)

---

### Electronic Regulator

Item	Description	Function
1	10x green LED	Pressure dew point indicator
2	Green area	Pressure dew point normal
3	Red area	Pressure dew point is too high
4	Green LED	Compressed air drier is turned on In the setting mode the blinking LED shows which data will be displayed
5	Yellow LED	Condensate magnetic valve is active
6	Yellow LED	Ventilator is turned on
7	Setting switch	Multi-function key for editing the parameter. <b>Press the button for 2 seconds:</b> Switch from display to setting mode <b>Briefly press the button:</b> Switch between menus <b>Press button together with up key:</b> Current setting is changed
8	Up key	Up / deflector test Pressing the up key will exit the setting mode

## Appendix KT refrigerant drier (cont.)

---

### Maintenance



**Before completing any maintenance work, please follow all safety provisions for electrical systems and electrical devices (see Chapter 1 of the original operating manual).**

The compressed air refrigerant drier must be maintained at different intervals. The maintenance intervals heavily depend on the utilisation type and the conditions of the installation site. The following maintenance work must be completed daily:

1. Check the function of the steam trap; check if water is drained; valve test (manual drain condensation):
2. Check the pressure dew point display; for deviations from the normal range, see chapter 5.2.2 and 5.2.3 in the original operating manual
3. Check the compressor for contamination

**Specific notes about other maintenance intervals and work can be found in the manufacturer original operating manual under Point 5 Maintenance.**

# Appendix AD

## Compressed air receiver

Illustration:  
air receiver



Description  
of air receiver

No.	Description	Function
1	<b>Connection from compressor</b>	Inlet of compressed air into the air receiver
2	<b>Safety valve</b>	Protects the air receiver against too high a pressure
3	<b>Compressed air outlet</b>	Outlet of compressed air to the c.a. system
4	<b>Condensate drain</b>	Drains the condensate for collection

- Please observe the regional laws and regulations for the control of air receivers and notice the periodic inspections
- Please take care for a condensate drain system
- Please take the necessary measures as to discharge the condensate if no automatic system

### Caution!

To grant the functionality of the air receivers, all flexible hoses of the receivers have to be changed after 2 years at the latest. This affects especially the 2 x 90l air receivers. Both receivers have to be able to be discharged separately.

The number of load changes in the air receiver should not be too high. Therefore, the compressor is not disconnected from the mains and do not let the pressure in the receiver fall too low. (purchase quantity < delivery quantity)

